

BAYT 980

Oil-hydraulic

Oil-hydraulic road barrier for traffic control from 3 to 8 metres

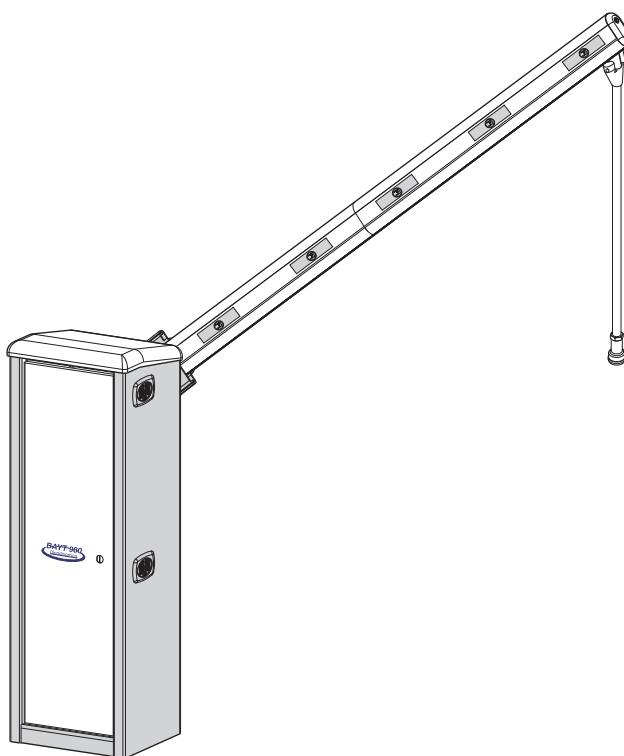

03.2026



EN 13241
EN 12453
EN 12445

Made in Italy



GENERAL WARNINGS FOR PEOPLE SAFETY**THANK YOU**

Thank you for purchasing a Fadini product.

Please read these instructions carefully before using this appliance. The instructions contain important information which will help you get the best out of the appliance and ensure safe and proper installation, use and maintenance. Keep this manual in a convenient place so that you can always refer to it for the safe and proper use of the appliance.

INTRODUCTION

This operator is designed for the specific scope of applications as indicated in this manual, it includes safety, control and signaling accessories as minimum required and Fadini equipment. □ Any applications not explicitly included in this manual may cause operation problems or damages to properties and people. □ Meccanica Fadini S.r.l. is not liable for damages caused by the incorrect use of the equipment, or for applications not included in this manual or for malfunctioning resulting from the use of materials or accessories not recommended by the manufacturer. □ The manufacturer reserves the right to make changes to its products without prior notice. □ All that is not explicitly indicated in this manual is to be considered not allowed.

BEFORE INSTALLATION

Before commencing operator installation assess the suitability of the access, its general condition and the structure. □ Make sure that there is no risk of impact, crushing, shearing, conveying, cutting, entangling and lifting situations, which may prejudice people safety. □ Do not install near any source of heat and avoid contacts with flammable substances. □ Keep all the accessories able to turn on the operator (transmitters, proximity readers, key-switches, etc) out of the reach of the children. □ Transit through the access only with stationary operator. □ Do not allow children and/or people to stand in the proximity of a working operator. □ To ensure safety in the whole movement area of a gate it is advisable to install photocells, sensitive edges, magnetic loops and detectors. □ Use yellow-black strips or proper signals to identify dangerous spots. □ Before cleaning and maintenance operations, disconnect the appliance from the mains by switching off the master switch. □ If removing the actuator, do not cut the electric wires, but disconnect them from the terminal box by loosening the screws inside the junction box. □ Make sure that in the near proximity or inside the installation accessories there aren't any electromagnetic sources of disturbance, such that they can cover or affect the magnetic/electromagnetic detections of possible loop detectors as well as of all of the electronic units that command and control the system.

INSTALLATION

All installation operations must be performed by a qualified technician, in observance of the Machinery Directive 2006/42/CE and safety regulations EN 12453 - EN 12445. □ Verify the presence of a thermal-magnetic 0,03 A - 230 V - 50 Hz circuit breaker where the main electric source of power of the installation is located. □ Use appropriate objects to test the correct functionality of the safety accessories, such as photocells, sensitive edges, etc.

□ Carry out a risk analysis by means of appropriate instruments measuring the crushing and impact force of the main opening and closing edge in compliance with EN 12445. □ Identify the appropriate solution necessary to eliminate and reduce such risks. □ During the rotation of the beam there must not be obstacles or points of contact that interfere with the movement. □ In case where the gate to automate is equipped with a pedestrian entrance, it is appropriate to prepare the system in such a way to prohibit the operation of the engine when the pedestrian entrance is used. □ Apply safety nameplates with CE marking on the gate warning about the presence of an automated installation. □ The installer must inform and instruct the end user about the proper use of the system by releasing him a technical dossier, including: layout and components of the installation, risk analysis, test of safety accessories, test of impact forces and report of residual risks.

INFORMATION FOR END-USERS

The end-user is required to read carefully and to receive information concerning only the operation of the installation so that he becomes himself responsible for the correct use of it. □ The end-user shall establish a written maintenance contract with the installer/maintenance technician (on -call). □ Any maintenance operation must be done by qualified technicians. □ Keep these instructions carefully.

WARNINGS FOR THE CORRECT OPERATION OF THE INSTALLATION

To achieve a long lasting performance of system in compliance with the safety regulations, it is necessary that proper maintenance and monitoring of the entire installation be performed: including the automation, the electronic equipment and the cables connected to these. □ The entire installation must be carried out by qualified technical personnel, filling in the Maintenance Manual indicated in the Safety Regulation Book (to be requested or downloaded from the site www.fadini.net/supporto/downloads). □ Operator: maintenance inspection at least every 6 months, while for the electronic equipment and safety systems an inspection at least once every month is required. □ The manufacturer, Meccanica Fadini S.r.l., is not responsible for non-observance of good installation practice and incorrect maintenance of the installation.

DISPOSAL OF MATERIALS

Dispose properly of the packaging materials such as cardboard, nylon, polystyrene etc. through specializing companies (after verification of the regulations in force at the place of installation in the field of waste disposal). Disposal of electrical and electronic materials: remove and dispose through specializing companies, as per Directive 2012/19/UE. Disposal of substances hazardous for the environment is prohibited.

**CE DECLARATION OF CONFORMITY of the manufacturer:**

Meccanica Fadini S.r.l. (Via Mantova, 177/A - 37053 Cerea - VR - Italy) declares under own responsibility that: **Bayt 980** complies with the 2006/42/CE Machinery Directive, and also that it is sold to be installed in an "automatic system", along with original accessories and components as indicated by the manufacturing company. An automatic gate operator is, by law, a "machinery" and therefore the installer must fit the equipment with all of the applicable safety norms. The installer is also required to issue the installer's Declaration of Conformity. The manufacturer is not liable for possible incorrect use of the product. The product complies with the following specific norms: analysis of the risks and subsequent action to cure them as per EN 12445 and EN 12453, Low Voltage Directive 2014/35/UE, Electromagnetic Compatibility 2014/30/UE. In order to certify the product, the manufacturer declares under own responsibility the compliance with the EN 13241-1 PRODUCT NORMS.

Meccanica Fadini S.r.l.
Director in charge



MAIN ELEMENTS FOR THE INSTALLATION OF A ROAD BARRIER BEAM

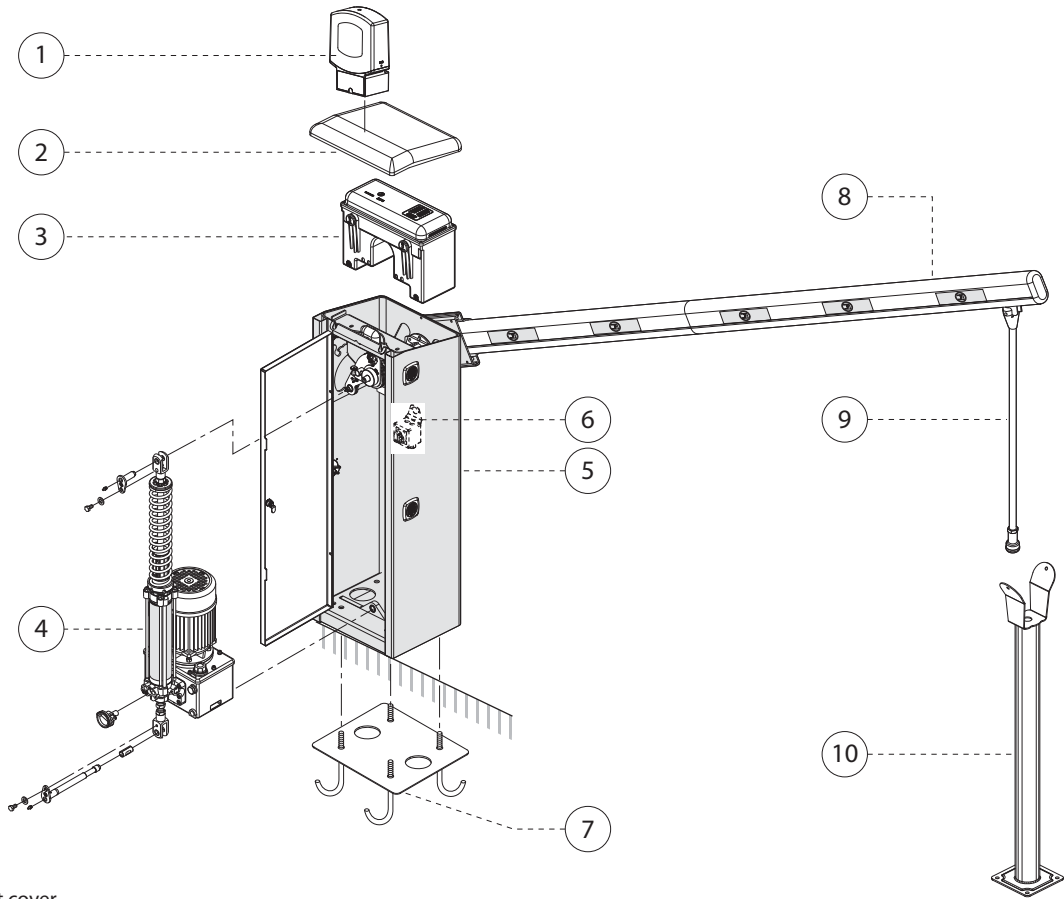

- 1. Flasher
- 2. Housing cabinet cover
- 3. Accessory box with control unit
- 4. Cos 982 main assembly with hydraulic piston and oil reservoir
- 5. Barrier cabinet - right hand version
- 6. Line switch for power supply
- 7. Anchor plate with anchor bolts
- 8. R532 beam arm in anodised aluminium, made up of two modules: 2,10 m + 3,20 m
- 9. Folding leg (optional)
- 10. Fixed pedestal with beam catcher (optional)

Pic. 1

RECOGNITION OF THE RIGHT AND LEFT HANDED BAYT 980

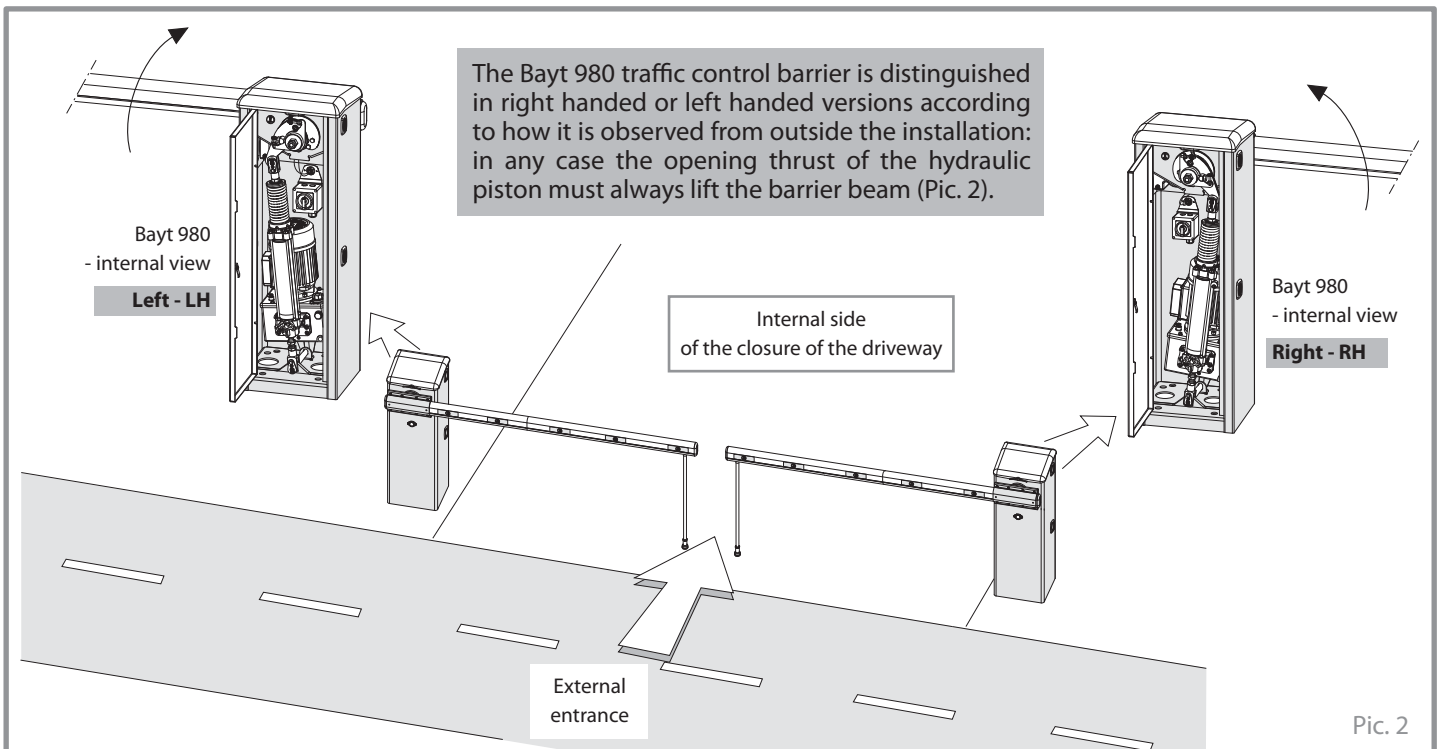

Pic. 2

INSTALLATION OF THE ANCHORING PLATE INTO THE GROUND

The first operation to be carried out is the cementing of the anchor plate into the ground on a levelled surface obtained through the pouring of a cement slab, paying attention that the longer side corresponds to the cabinet door side. It is necessary then to arrange one or two flex conduit tubes with a 50 mm diameter, which will enable the later passage of the electrical service cables (electrical powering of the system and for the command and safety accessories), as illustrated in Pic. 3.

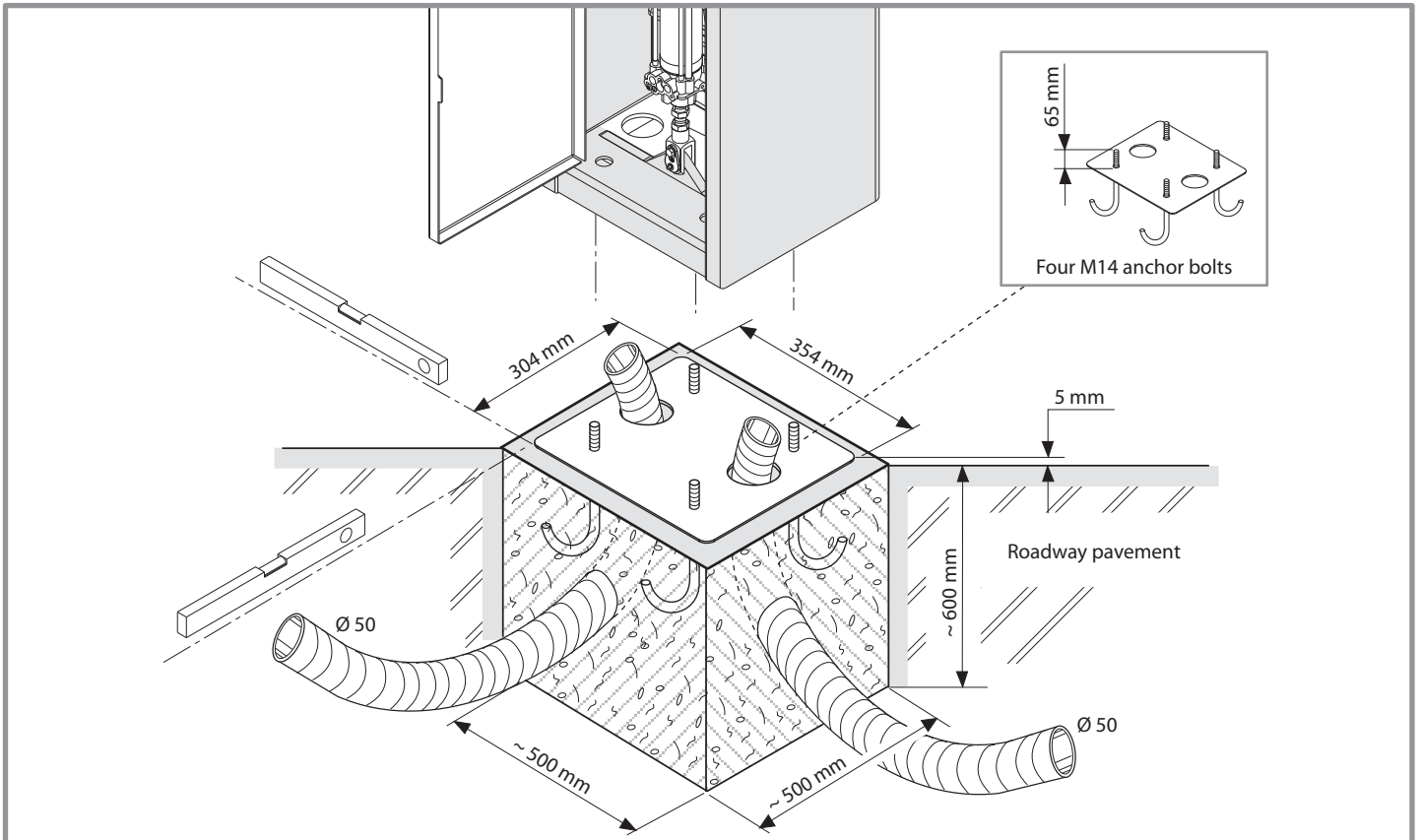

! **Important:** screw the anchor bolts into the anchor plate before cementing it in its site, so that the respective threads protrude completely.
Important: the anchor plate must be perfectly levelled before it is cemented. Use a level in both directions to achieve alignment. Furthermore, it must be set **5 mm higher** than the level of the roadway pavement (Pic. 3).

Pic. 3

INSTALLATION OF THE ANCHORING PLATES FOR TWO BARRIERS

For installations that require two Bayt 980 roadway barriers it is necessary to arrange an underground electrical conduit between the two housing cabinets, for the connection of the photocells or other accessories and for the service cabling (Pic. 4).

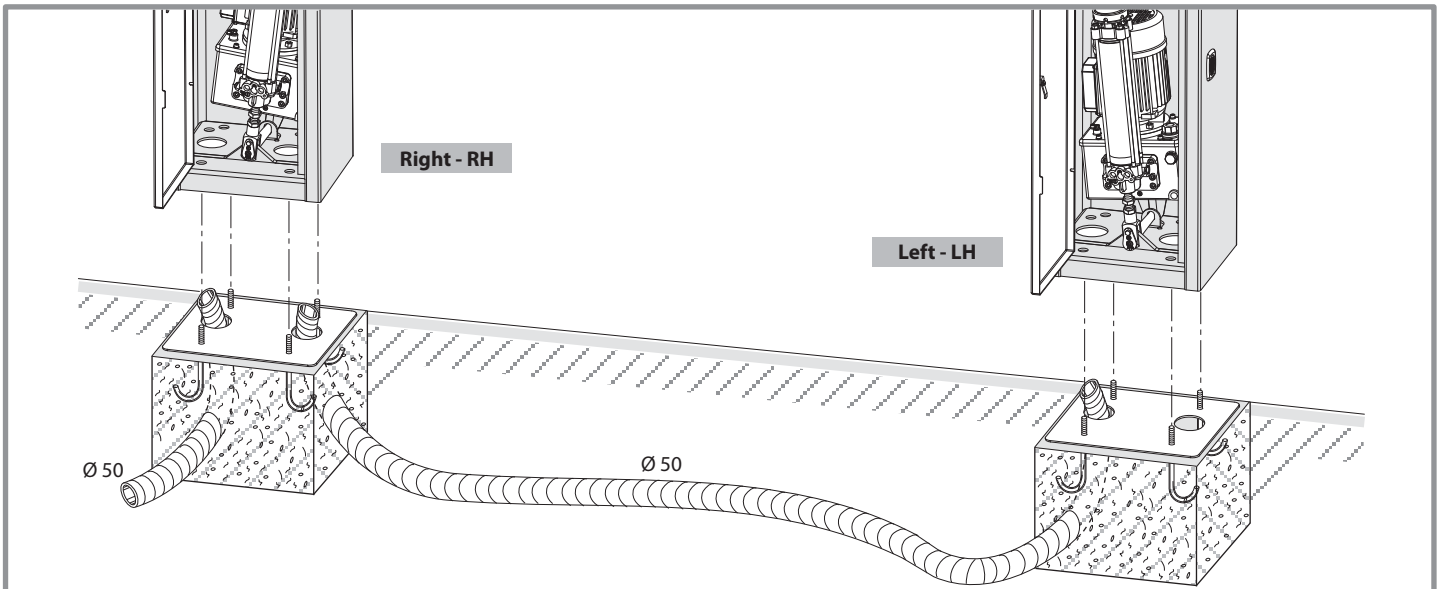

Pic. 4

FIXING THE HOUSING CABINET

Once satisfied the anchor plate has firmly set into the ground (it is necessary to wait until the concrete has hardened), the Bayt 980 housing cabinet can be mounted onto it and then the four M14 hexagonal nuts can be securely tightened with their respective washers (onto the anchor bolts protruding from the base of the cabinet) as illustrated in Pic. 5.

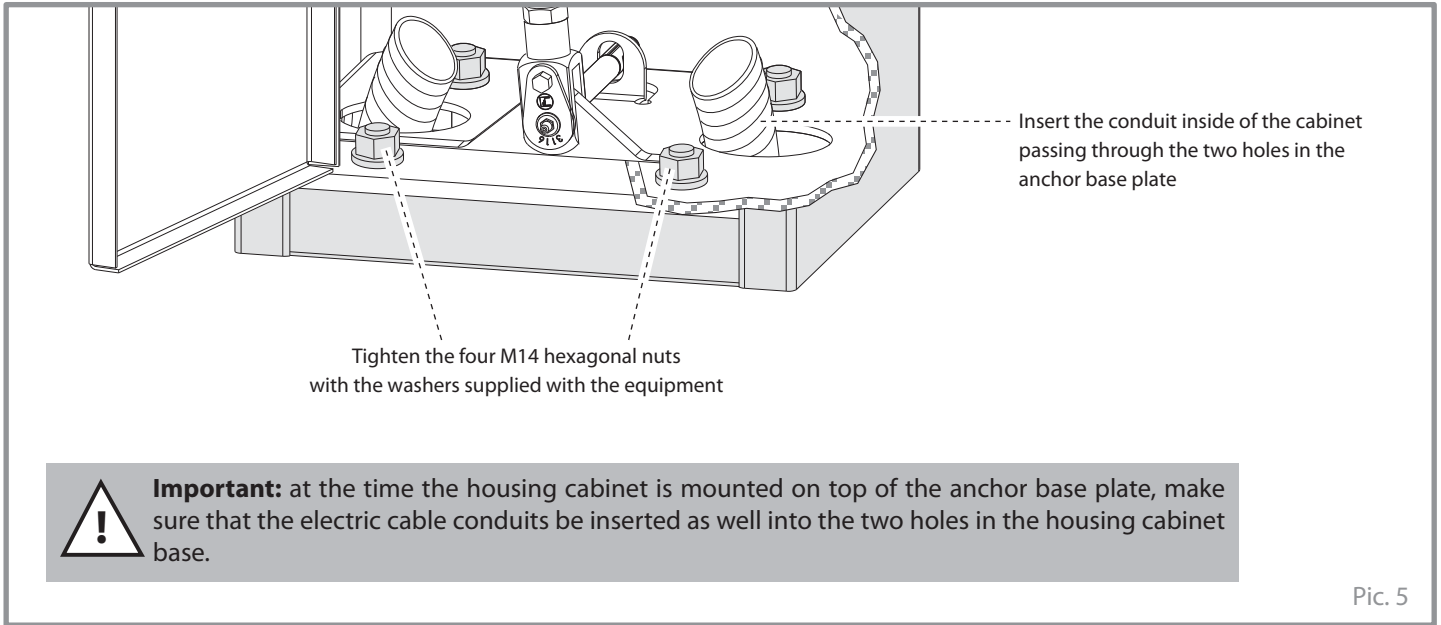

INSTALLATION OF THE FIXED PEDESTAL WITH BEAM CATCHER

With the installation of the fixed pedestal with beam catcher, it is necessary to lay down a service conduit between the barrier and the fixed pedestal for the passage of the electrical cables of the photocells or a possible magnetic lock (optional) to secure the aluminium barrier beam; this operation must be performed after having set the Bayt 980 foundation plate, where the edge lines of the barrier housing cabinet and fixed pedestal base plate respectively must be perfectly aligned (Pic. 6).

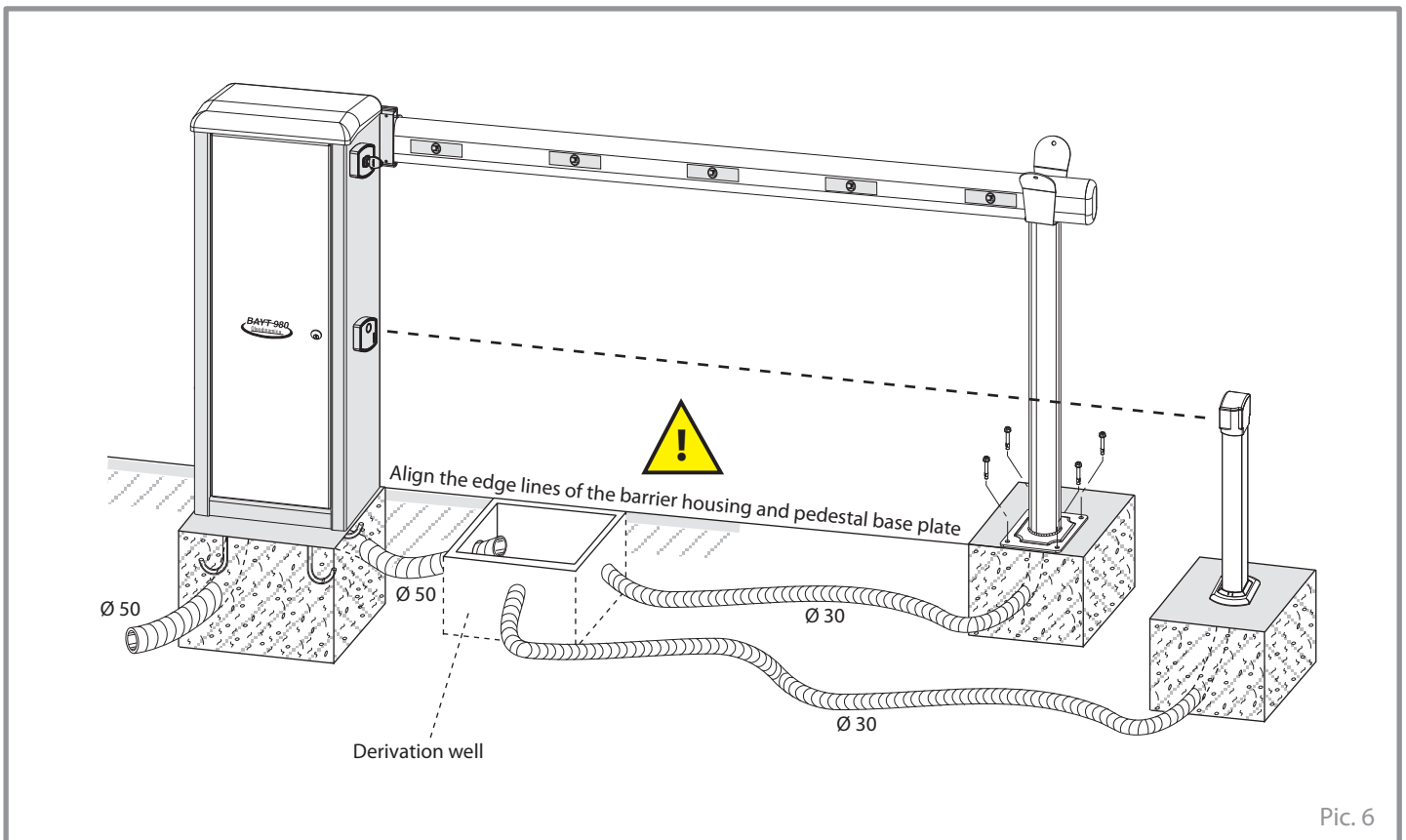

MAIN COMPONENTS FOR THE BAYT 980 ELECTRICAL SYSTEM

IMPORTANT: All of the electrical connections and cabling must be carried out to the rules of the art, in observance of the good technique of installation, according to the safety regulations in force (Machine Directive 2006/42/CE) and must be performed by qualified technical personnel, formulating a complete risk analysis and adopting suitable safety measures in the filling out of the technical file, according to the to the EN 12445 and EN 12453 regulations. For the electrical power supply of the electric motor and the flasher, electrical cables with a section of 1 mm² will have to be utilised for a maximum distance of 50 metres. For distances longer than 50 metres, it is recommended that cables with sections suitable for a proper standard of installation be used. For all of the accessories external to the electrical control panel, electrical cables with wires of a section of 0,5 mm² may be utilised.

English

1. 230 V - 50 Hz, 0,03 A magneto-thermic differential line switch (not provided by the manufacturer). Beyond 100 m distance, cable section to be 2,5 mm²
2. Flasher with
3. Built-in key-switch
4. Built-in photocell receiver
5. Bayt 980 hydraulic barrier with programmer and plug-on radio card
6. Pedestal with beam catcher
7. Built-in photocell projector
8. Post with photocell
9. Transmitter

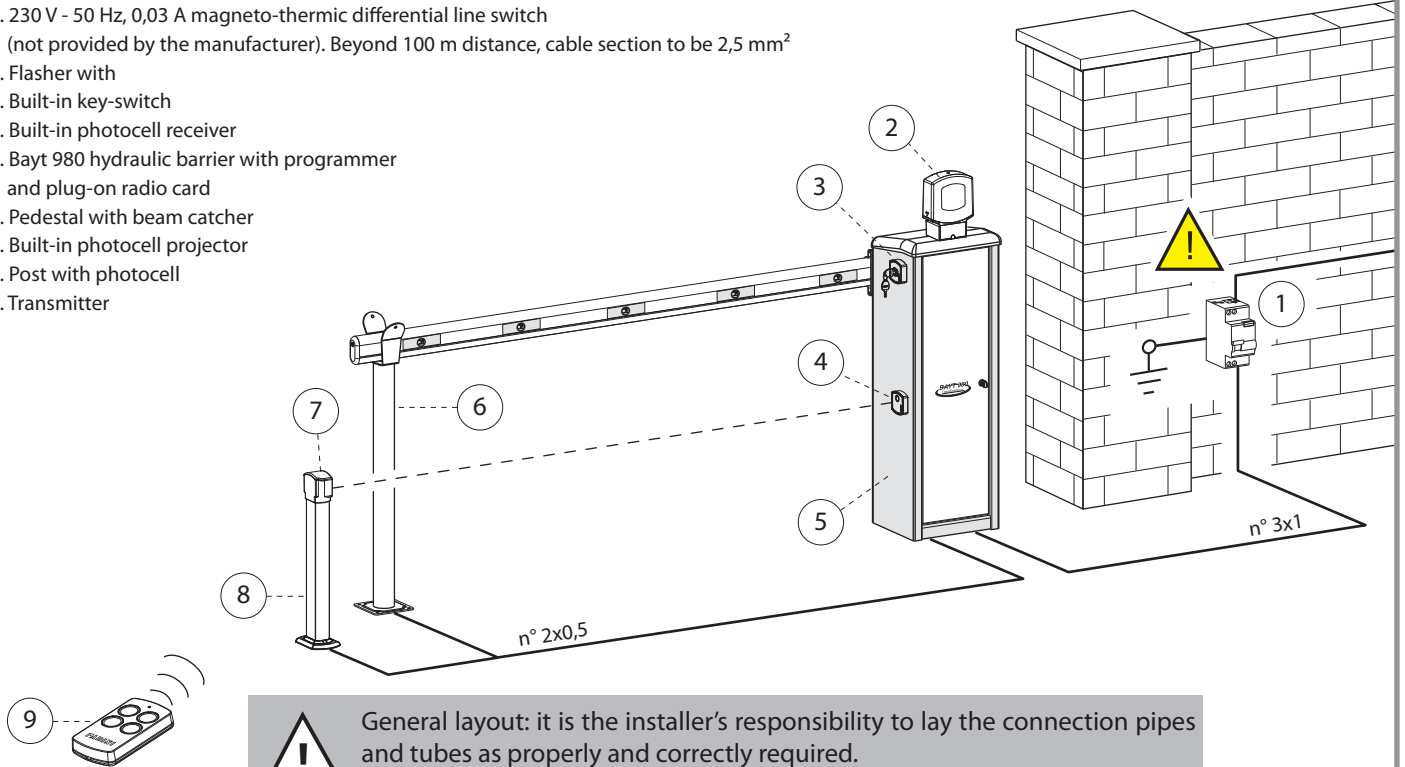

! General layout: it is the installer's responsibility to lay the connection pipes and tubes as properly and correctly required.
Important: the entire system must be connected to earth.

Pic. 7

HOW TO TURN A LEFT HANDED BAYT INTO A RIGHT HANDED BAYT AND VICE VERSA

This operation is necessary in case a previously supplied Bayt 980 be required to be converted to meet the installation requirements or on the customer's request.

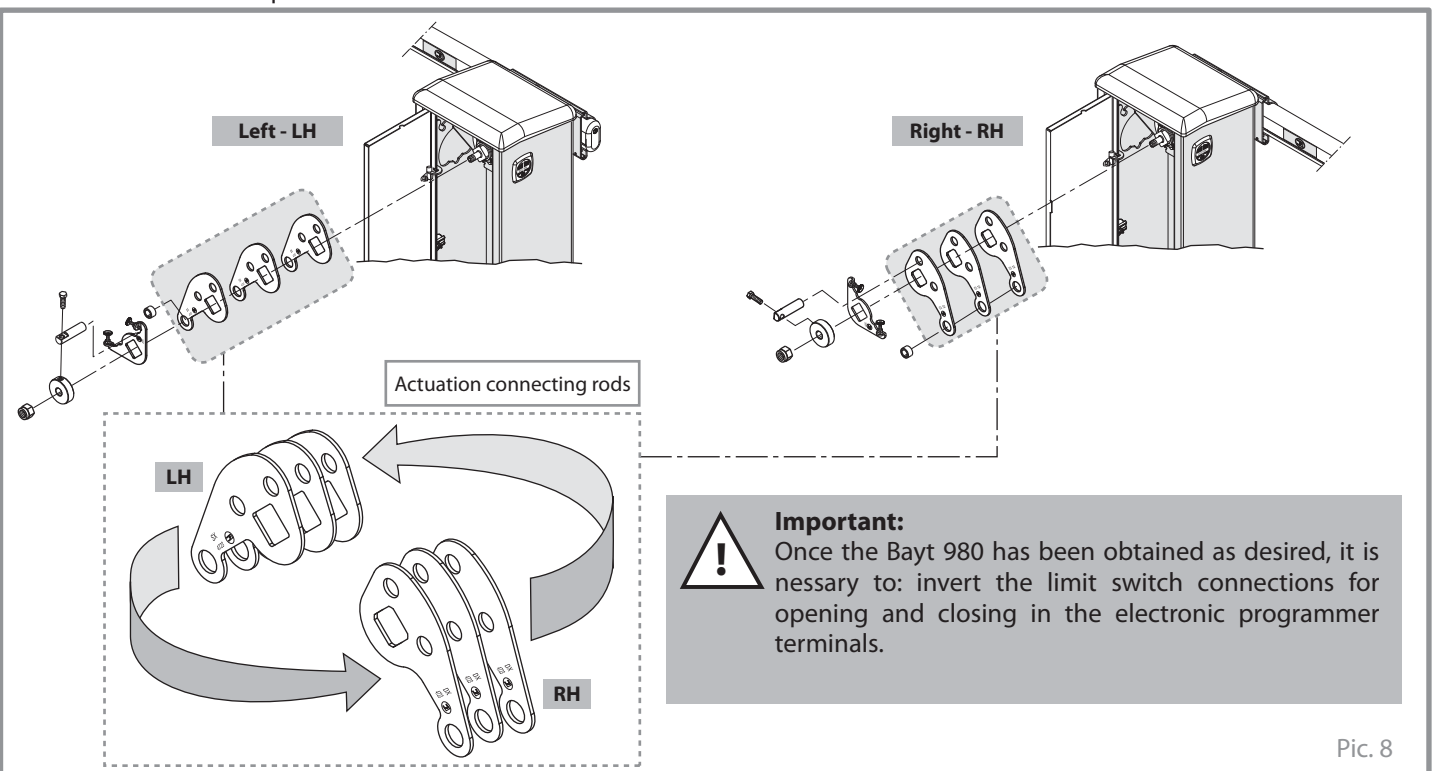

! **Important:** Once the Bayt 980 has been obtained as desired, it is necessary to: invert the limit switch connections for opening and closing in the electronic programmer terminals.

Pic. 8

INSTALLATION OF THE BARRIER BEAM AND POSSIBLE COMBINATIONS

The R532 aluminium barrier beam is attached to the beam clamp located on the side of the housing cabinet, facing the entrance that is to be controlled with the barrier. To perform this operation it is first of all necessary to loosen the eight attachment screws in the beam clamp and then insert the barrier beam, so that the end with the black plastic cap extends slightly beyond the clamp, and then finally tighten the attachment screws (Pic. 9). In particular situations, it might be necessary having to remove the clamp in order to fit the beam.

Pic. 9

Union of the two R532 barrier beams with the expandable coupling clamp

2,10 metres

3,20 metres

R532 aluminium barrier beam

Coupling clamp

The union of the two barrier beams is possible utilising the coupling clamp, which has the characteristic of expanding when the screws are tightened and contracting when the screws are loosened (Pic. 10).

1 Loosen the screws located underneath the coupling clamp

2 Insert the coupling clamp to the halfway point (note the horizontal arrow indicators)

3 Insert the other barrier beam section until it contacts the first and then tighten the clamp screws

Pic. 10

Net length **L**

Actual length **X**

POSSIBLE COMBINATIONS: the R532 barrier beam is provided in two modules: of 2,10 metres and of 3,20 metres, with the possibility of making up barrier beams of different lengths, as represented in the table in Pic. 11.

Actual length maximum dimensions - X (metres)	Net length for the roadway - L (metres)
Barrier beam 3,20	2,85
Barrier beam 2,10 + 2,10 = 4,20	3,85
Barrier beam 3,20 + 2,10 = 5,30	4,95
Barrier beam 3,20 + 3,20 = 6,40	6,05
Barrier beam 3,20 + 2,10 + 2,10 = 7,40	7,05
Barrier beam 3,20 + 3,20 + 2,10 = 8,50	8,15

Pic. 11

ATTACHMENT OF THE BAYT 980 FOLDING LEG

English

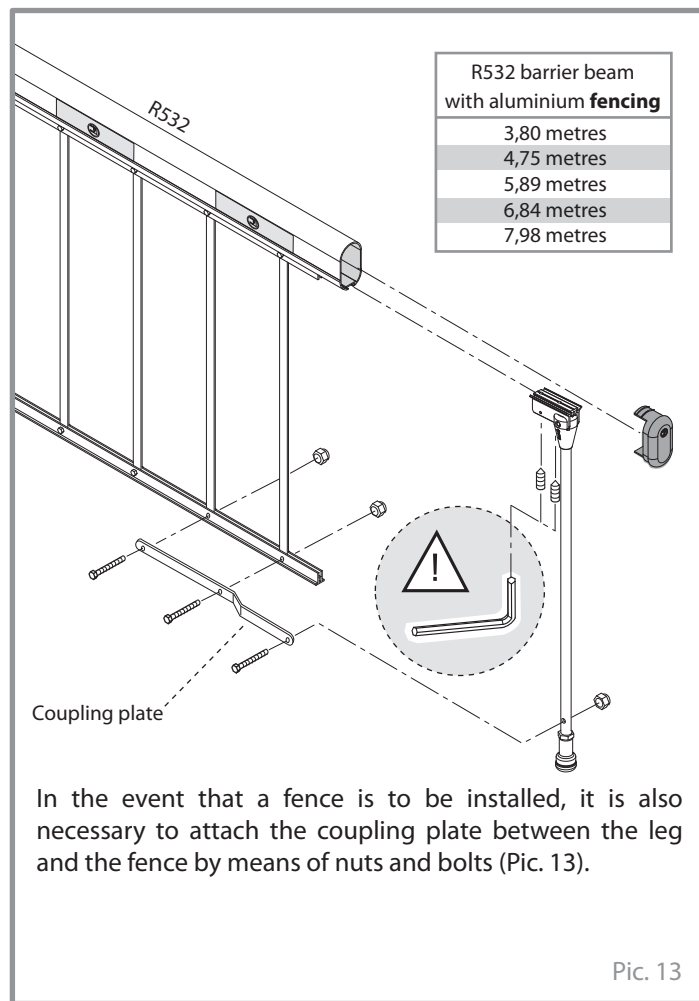
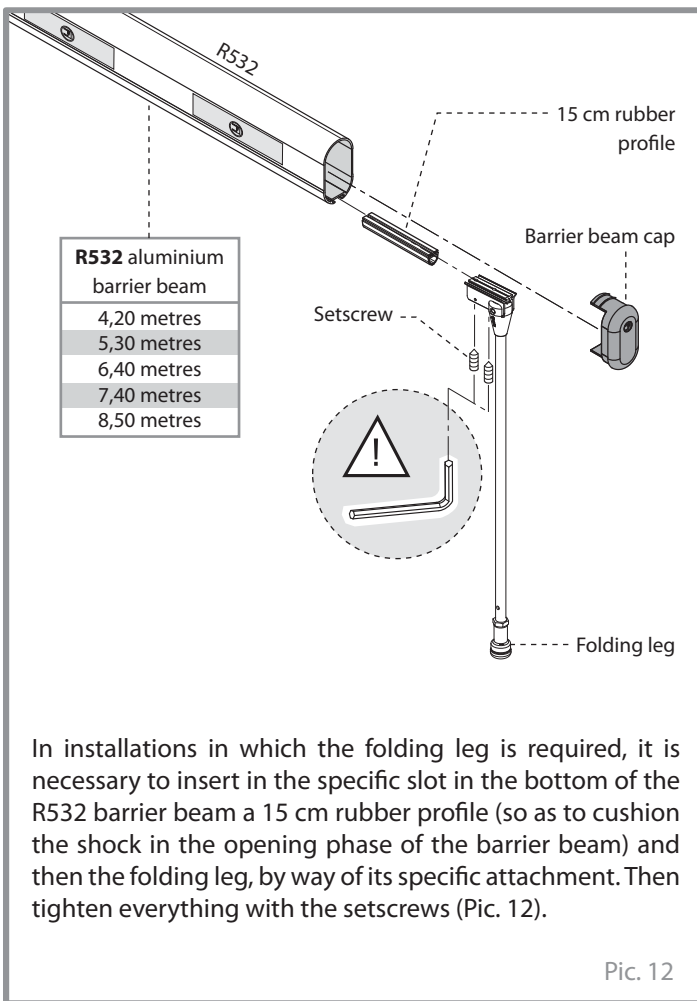

INSTALLATION OF COUNTERWEIGHTS ON THE BAYT 980

In Bayt 980 installations with beams that are 6,40 metres in length or longer and fitted with a fence, it is necessary to also attach counterweights by means of nuts, bolts and a support bracket (Pic. 14). See the summary table of the possible applications (Pic. 34, page 20).

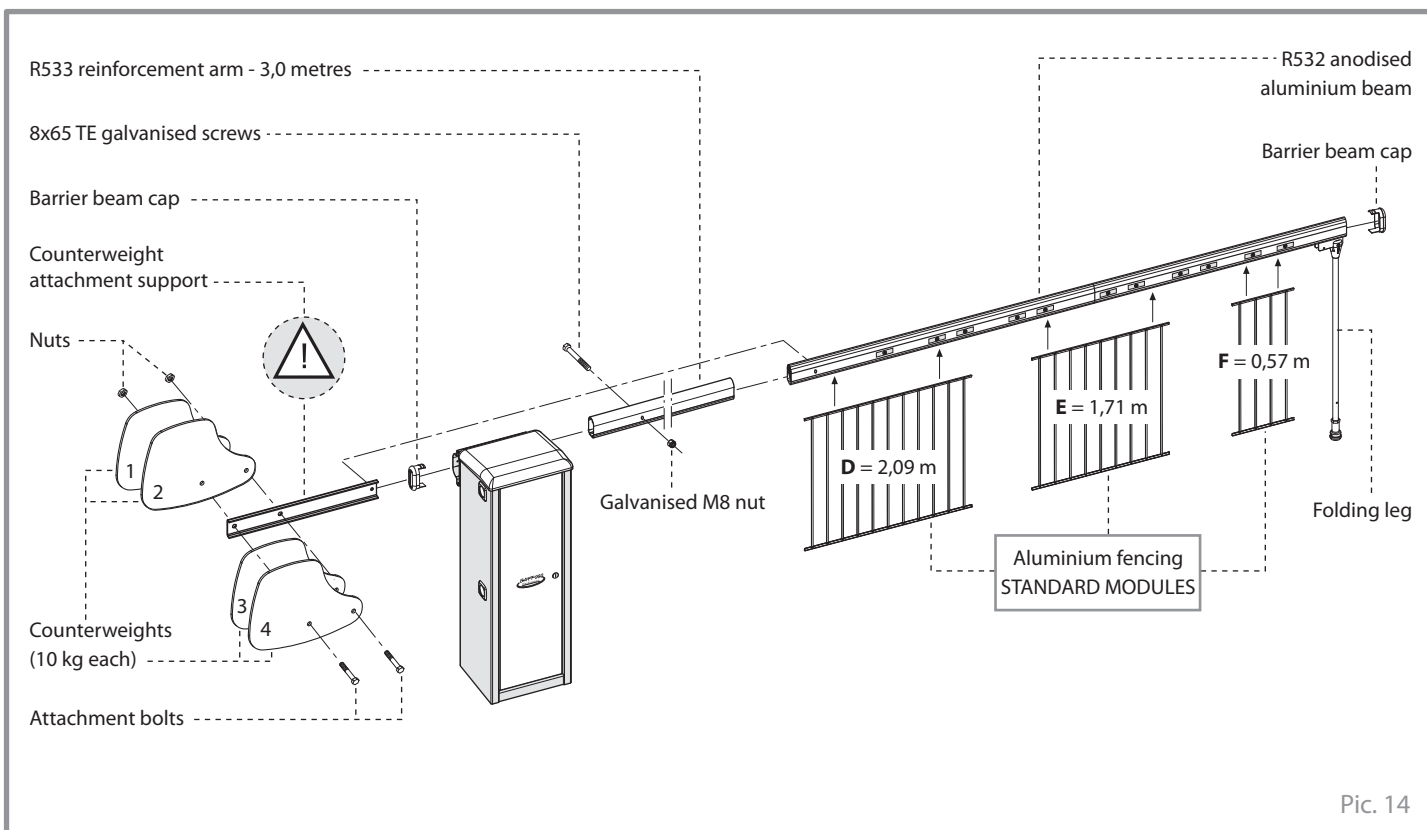

ATTACHMENT OF THE HINGED BARRIER BEAM TO THE HOUSING CABINET

According to the demands of the installation it is possible to apply a hinge coupling to Bayt 980 following the instructions in Pic. 15.

Ceiling height H	Barrier beam length A	Metal cable fixed length (supplied by the manufacturer) L	Opening time
2,50 m	1,60 m	1,25 m	4 s
2,70 m	1,80 m	1,45 m	4 s
2,80 m	1,90 m	1,55 m	4 s
3,00 m	2,10 m	1,75 m	8 s
3,70 m	2,80 m	2,45 m	8 s
4,10 m	3,20 m	2,85 m	8 s

The B barrier beam is provided in lengths of 2,10 metres or 3,20 metres according to width C as required.
Where C is the sum of A+B.

In case a BAYT 980 with articulated arm is required at the time of the order, it comes factory-preset for it.

Pic. 15

INSTALLATION OF THE BAYT 980 WITH MAGNETIC LOOP

Ref. code 2037L - 6 m circumference, pre-assembled loop.
Ref. code 2042L - 12 m circumference, pre-assembled loop.

Magnetic loop power supply cable, total length = 10 metres from the detector

Obstacle presence detector

Bayt 980

Magnetic loop power supply cable, total length = 10 metres from the detector

For those installations where one or two magnetic loops are required, it is recommended to follow the instructions included with the detector (Ref. drwg. 7038).

Pic. 16

PROCEDURE FOR DRILLING AND ATTACHING THE FLASHER ON THE CABINET COVER

- Loosen and remove the three M8 attachment screws (9 and 16) of the cabinet cover (6) - Pic. 18.
- Turn the cover (6) upside down and drill a 4,2 mm diameter hole in it and thread M5 the three studs (24) for the attachment of the flasher (1). Pic. 17.
- The central stud of the cover (23) must be drilled out with a 10,5 mm diameter bit to enable the passage of the electrical power supply cable for the flasher and for the insertion of the RG58 coaxial cable for the aerial - Pic. 17.
- Then run the electrical cables through the central 10,5 mm diameter hole and attach the vertical coupling (5) of the flasher (1) with the three M5 screws (4) on the outside of the cover - Pic. 18.
- Replace the cover on the housing cabinet (17) and attach it with the three M8 screws so as to cover the Bayt 980 cabinet, as shown in Pic. 18.

In order to install the photocells and the key-switch on the housing cabinet, it is necessary to remove the protective covers (22) unscrewing the M8 nut (20) from inside of the cabinet and then removing the stop plate (21) - Pic. 19. The housing cabinet is in this way prepared for the attachment of all of the operational accessories - Pic. 18.

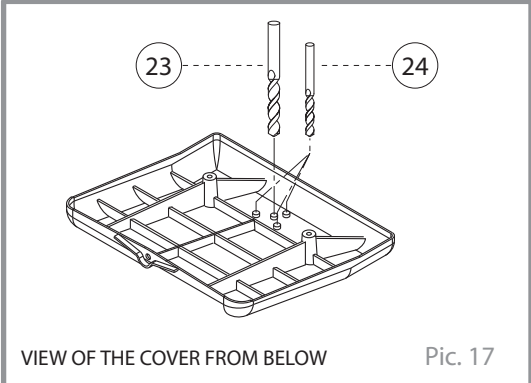
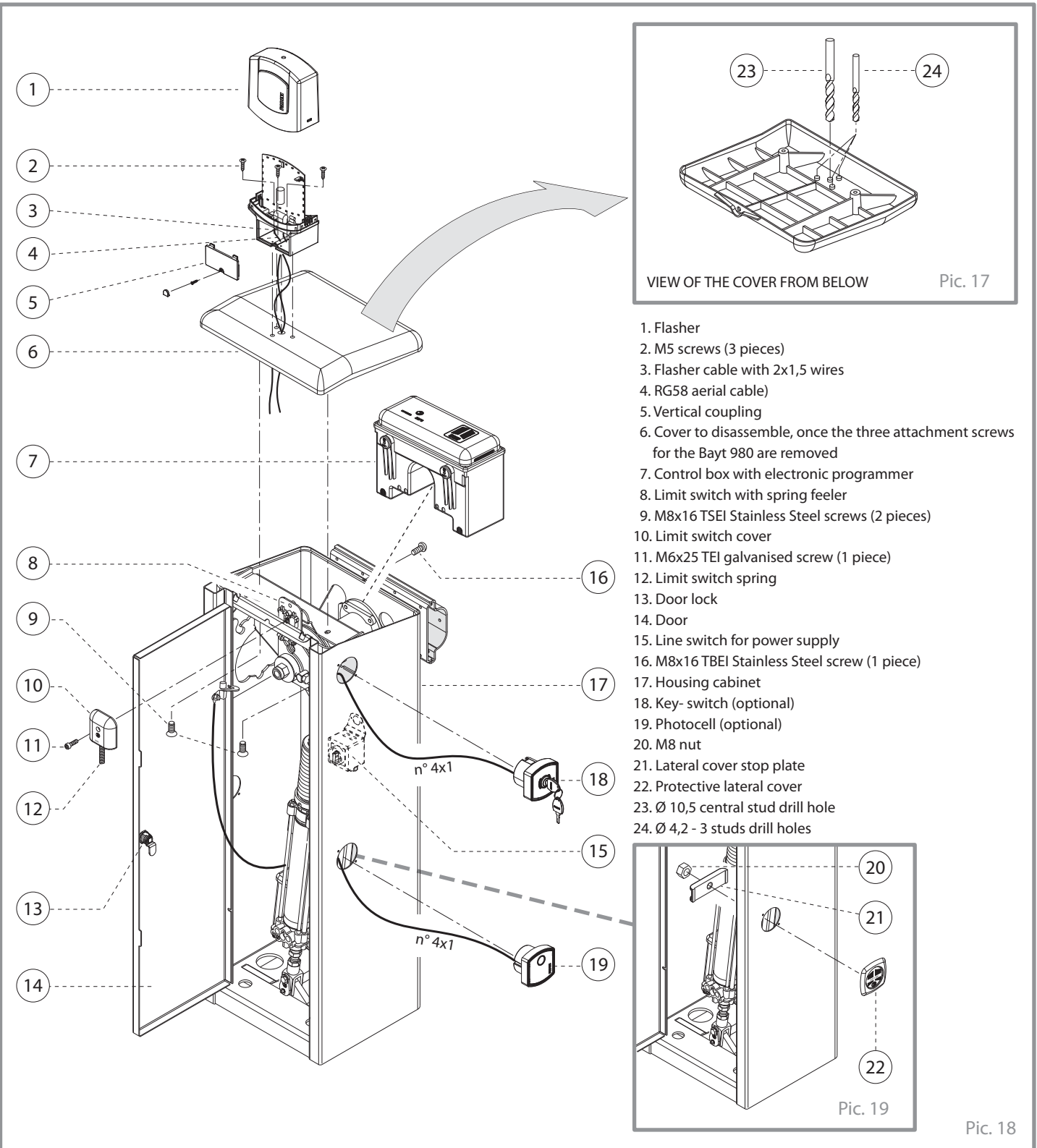

1. Flasher
2. M5 screws (3 pieces)
3. Flasher cable with 2x1,5 wires
4. RG58 aerial cable
5. Vertical coupling
6. Cover to disassemble, once the three attachment screws for the Bayt 980 are removed
7. Control box with electronic programmer
8. Limit switch with spring feeler
9. M8x16 TSEI Stainless Steel screws (2 pieces)
10. Limit switch cover
11. M6x25 TEI galvanised screw (1 piece)
12. Limit switch spring
13. Door lock
14. Door
15. Line switch for power supply
16. M8x16 TBEI Stainless Steel screw (1 piece)
17. Housing cabinet
18. Key- switch (optional)
19. Photocell (optional)
20. M8 nut
21. Lateral cover stop plate
22. Protective lateral cover
23. Ø 10,5 central stud drill hole
24. Ø 4,2 - 3 studs drill holes

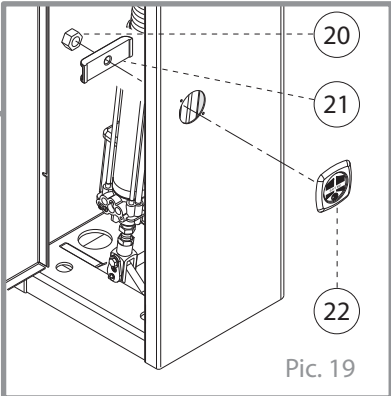

English

ELECTRICAL CONNECTIONS FOR 1 BAYT 980 TO THE ELPRO 980 PROGRAMMER

The main assembly Cos 982, voltage disconnect, limit switches and blue led light are factory pre-set. For a detailed explanation of all of the functions, including the automatic/semiautomatic operating modes, hold - on - switched command and clock connection, it is suggested that the Elpro 980 instructions book be referred to.

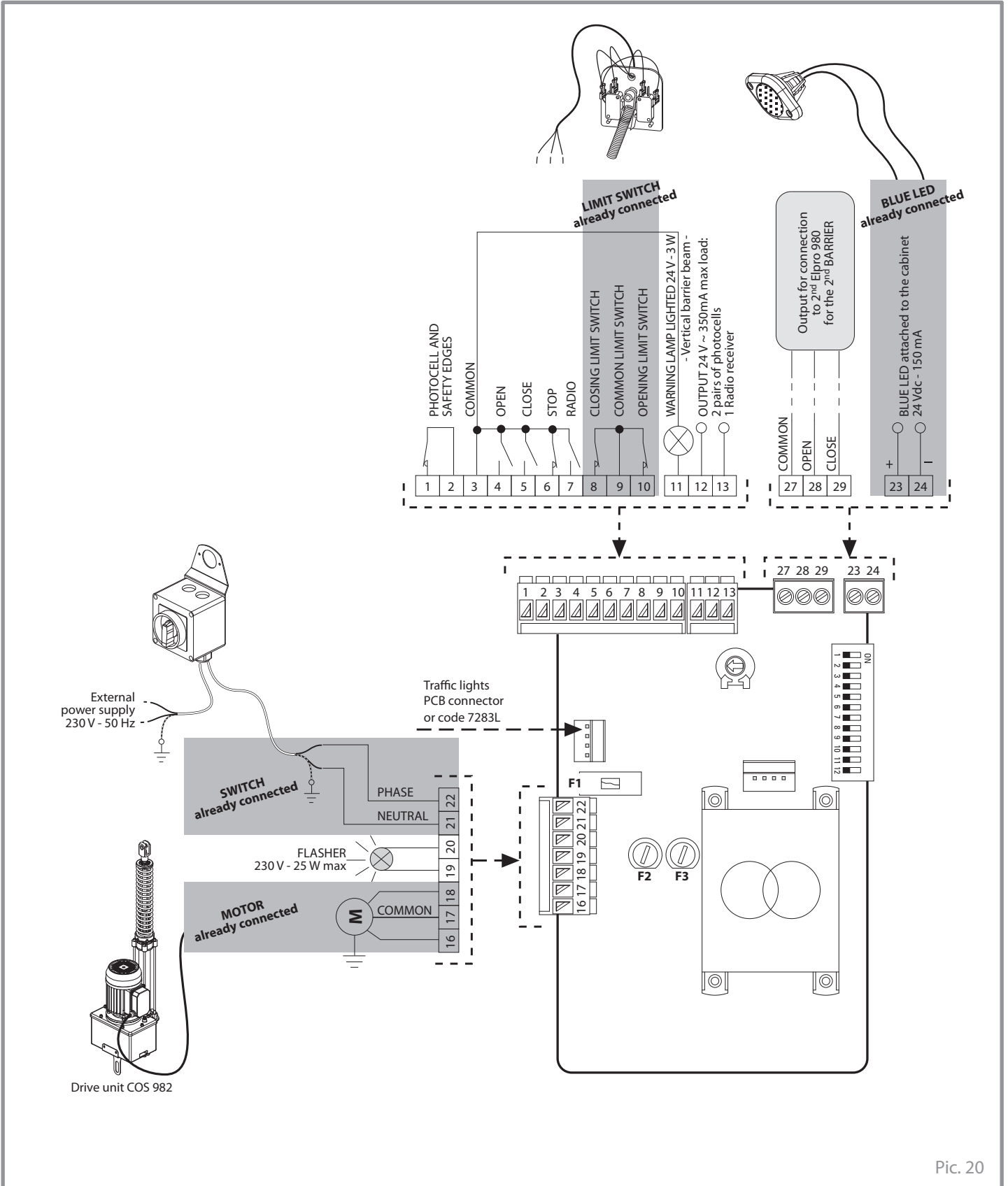
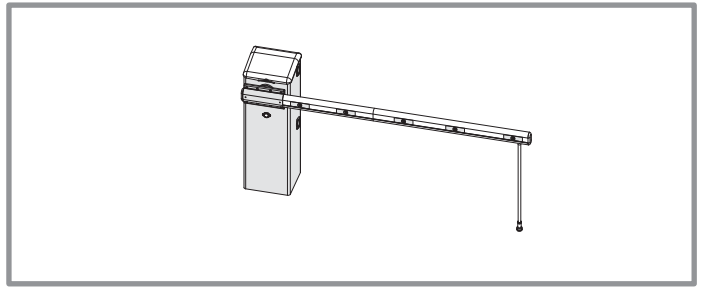

Pic. 20

ELECTRICAL CONNECTIONS FOR 2 BAYT 980s TO ELPRO 980 PCBs

English



Important: before completing all of the electrical connections as required, identify the Elpro 980 of the master barrier, which commands the Elpro 980 in the slave barrier.

In the case of simultaneous barriers it is suggested that they are set with an equal barrier beam length and speed, otherwise the master barrier between the two must be that with the longer barrier beam length or that with the slowest speed.

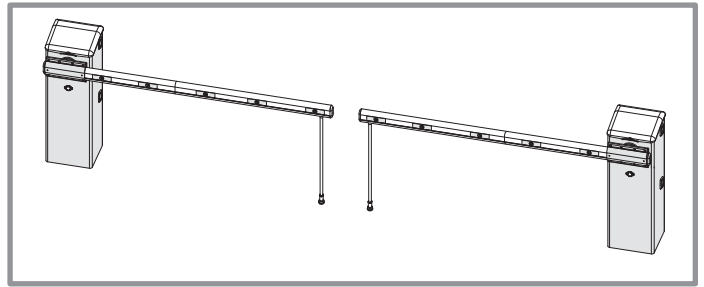

- **Elpro 980 master:** perform all of the connections necessary for the operation of the Bayt 980; any command accessories, radio PCB etc. must be connected exclusively to the Elpro 980 master.
- **Elpro 980 slave:** power the PCB, jump the NC connections (stop, photocell and safety switches) and finally connect the motor and the limit switches of the Bayt 980 slave. Set the dip-switch 12 = ON.
- Connect the 27, 28, 29 terminals of the Elpro 980 master respectively with the 3, 4, 5 terminals of the Elpro 980 slave.



Important: carry on the inter-connections between the two Elpro 980 master and slave PCBs

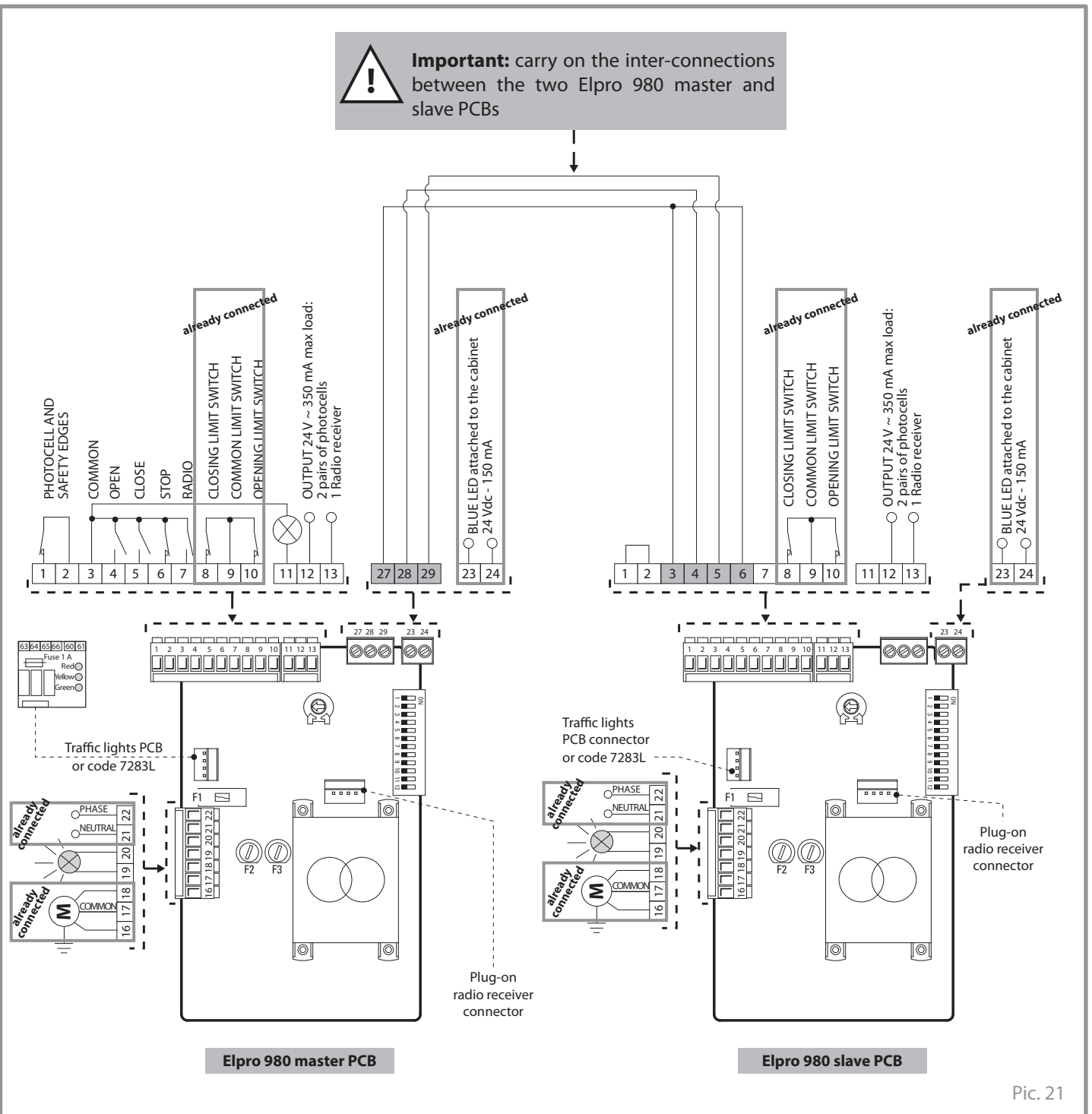

Pic. 21

ADJUSTMENT OF THE BARRIER BEAM IN HORIZONTAL AND VERTICAL POSITIONS

The Bayt 980 hydraulic barrier has a simple but effective adjustment system for the moving arm, in opening and in closing, as indicated in Pic. 22.

Important: the adjustment of the Bayt 980 arm is factory pre-set. Make sure of the absolute necessity of changing it at the time of the installation, and carry out some opening and closing operations before doing it.

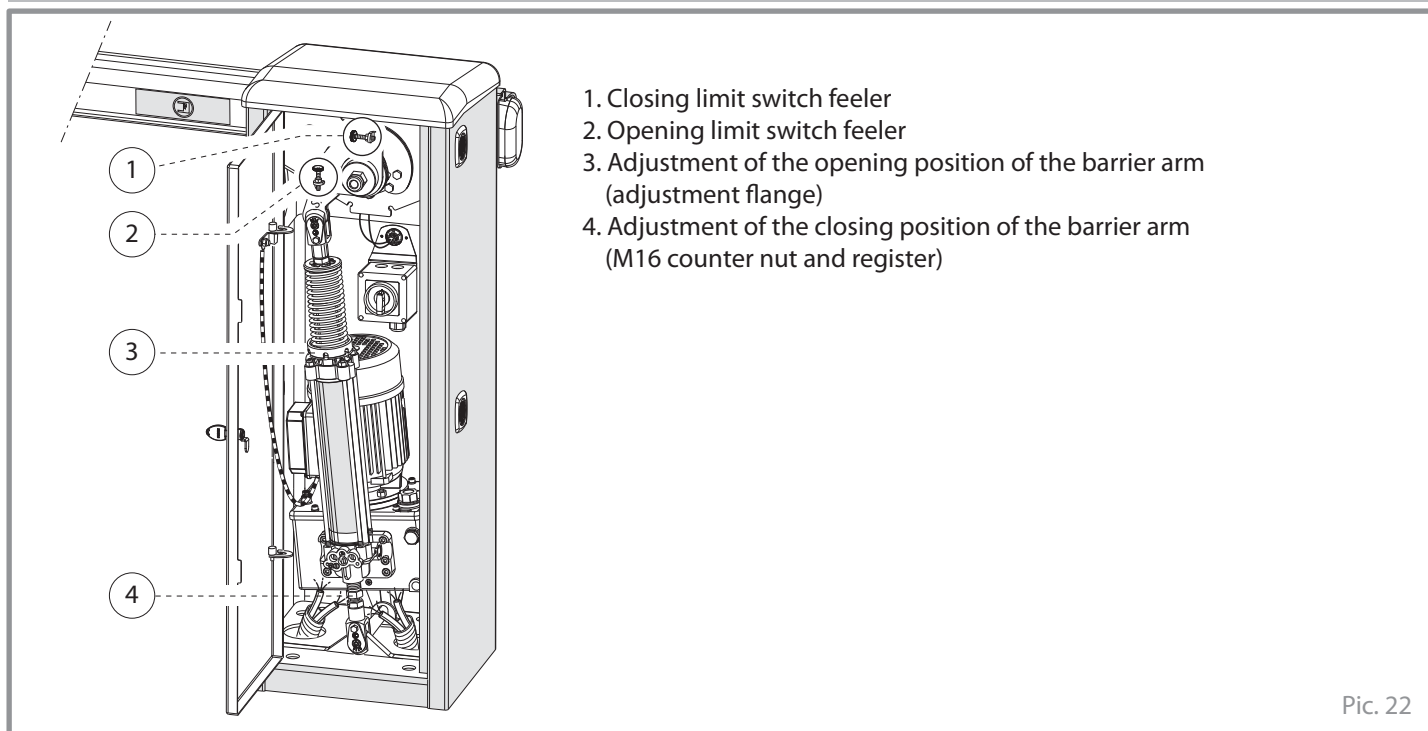

ADJUSTMENT OF THE BARRIER BEAM IN CLOSING POSITION (Pic. 23)

Important: the adjustment of the Bayt 980 arm is factory pre-set. Make sure of the absolute necessity of changing it at the time of the installation, and carry out some opening and closing operations before doing it.

In closed position, the barrier beam must be horizontal; therefore the adjustment is performed with the piston rod completely retracted.

Before starting a new adjustment, make sure the M16 lock nut (b) be tightened hard.

1. Screw the closing limit switch feeler (a) tighter, so it is no longer operating.
2. The M16 lock nut (d) must be loosened and then re-adjust by a 24 mm spanner (e).
3. Tighten clockwise the adjustment nut (c) by the 24 mm spanner so as to lower the barrier beam slightly beyond the "horizontal line".
4. Once the adjustment has been made, the M16 lock nut (d) previously loosened must be tightened, so as to lock the fork to the Bayt 980 base.
5. Unscrew the closing limit switch feeler (a) until the micro-switch snaps (when the beam is in horizontal position), then tighten the respective M6 lock nut hard.

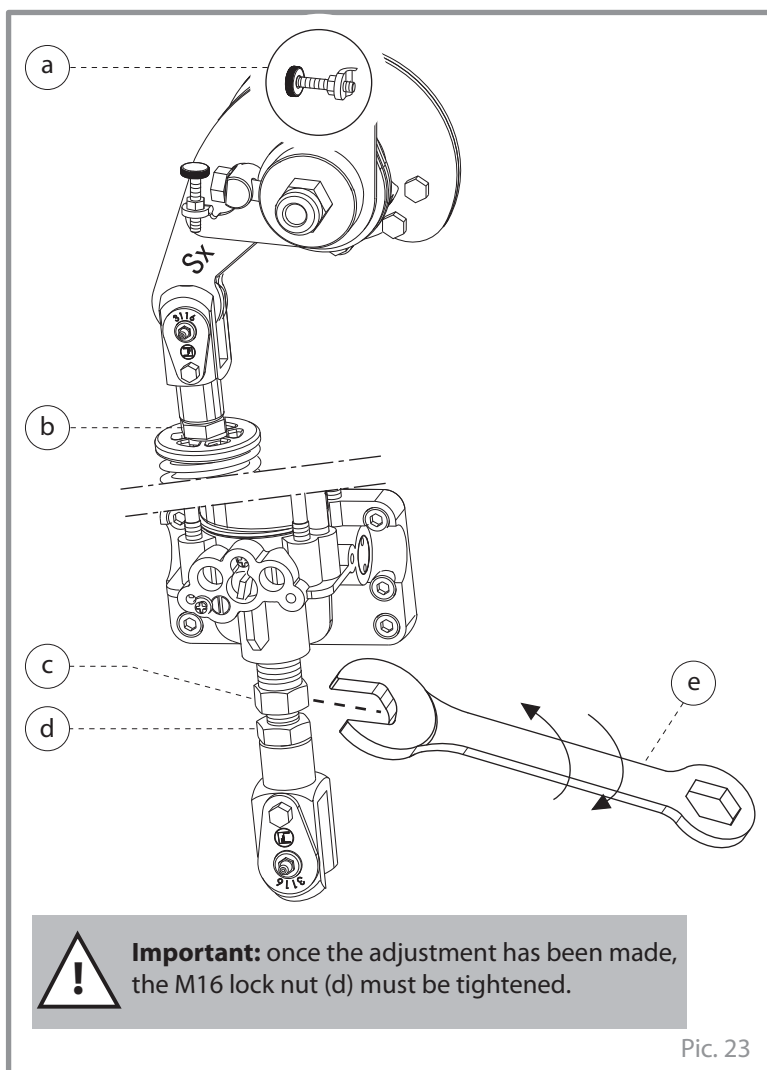

ADJUSTMENT OF THE BARRIER BEAM IN OPENING POSITION (Pic. 24)

English

! **Important:** the adjustment of the Bayt 980 arm is factory pre-set. Make sure of the absolute necessity of changing it at the time of the installation, and carry out some opening and closing operations before doing it.

! **Important:** with the barrier beam in an intermediate position at 45° and the piston rod therefore at its half stroke point, it is possible to adjust the barrier beam in the open position. Do not adjust with the barrier beam in the vertical or horizontal stop positions (Pic. 24).

1. Screw the opening limit switch feeler (a) tighter, so it is no longer operating.
2. Mechanical adjustment phase: position the beam at 45° and re-adjust by means of a screwdriver on the washer (b) positioned under the compression spring. Tighten the screw to the left to reduce the piston stroke (therefore the beam reaches the end of the permitted open position earlier - vertical position); unscrew to the right to increase the piston stroke (therefore the beam reaches the end of the permitted open position later - vertical position). It is recommended that the limit vertical position is adjusted beyond 90°; in this way the limit switch feeler is caused to operate before the very end of the permitted stroke.
3. Micro-switch adjustment phase: with the beam at 90° opening, unscrew the opening limit switch feeler (a) until the micro-switch snaps; after a command pulse to open has been given, tighten the respective M6 lock nut hard.

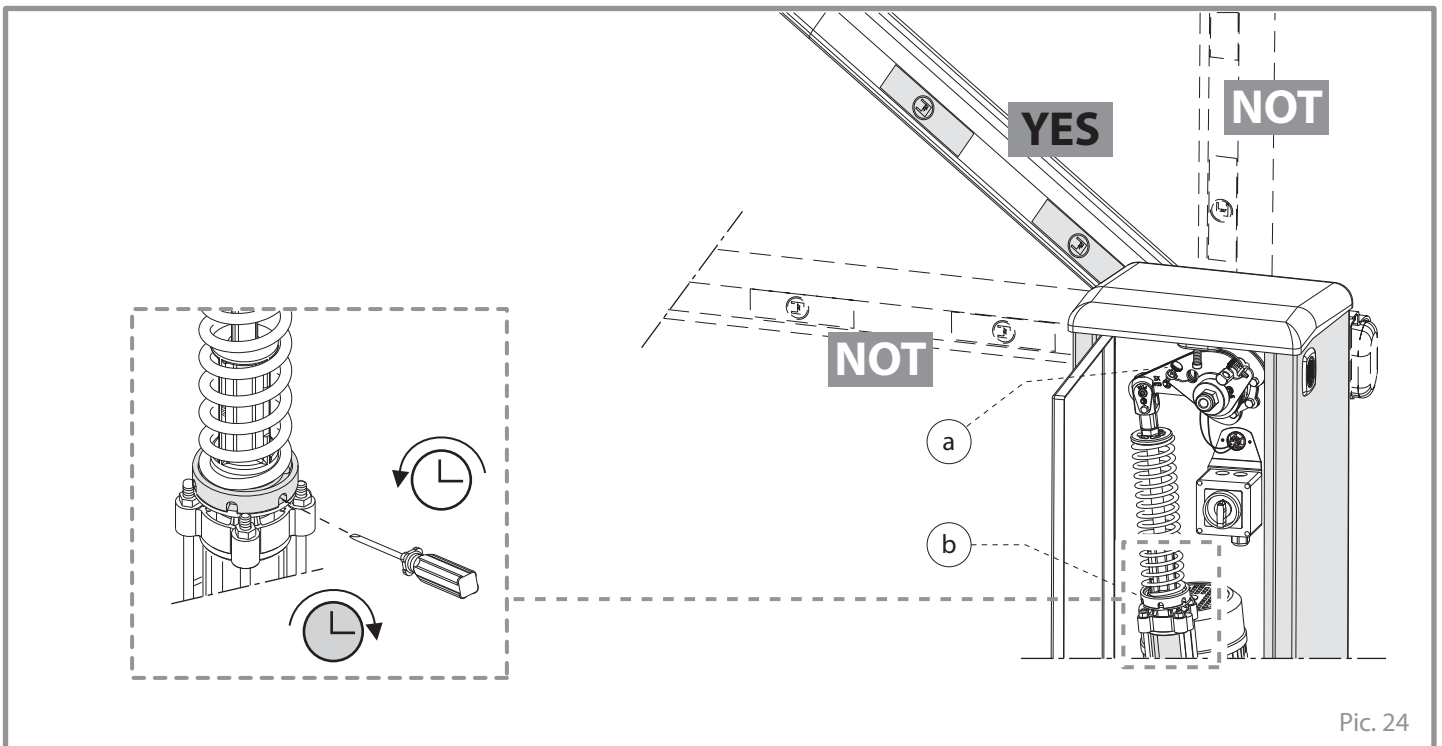

Pic. 24

ADJUSTMENT OF THE LIMIT SWITCHES

! **Important:** at the moment of the first running test at the factory, the position of the two feelers is correctly adjusted in accordance with the vertical and horizontal positions of the barrier beam in opening and closing respectively.

Once the procedure on the stop positions of the Bayt 980 barrier beam has been finished, it is possible to adjust the opening and closing limit switches by loosening the lock nuts of the adjustable ridged feelers, which operate the flexible limit switch levers. After having verified the correct operation of the flexible lever (both in vertical and in horizontal positions) on the limit switch micro-switch, it is necessary to securely tighten the respective lock nuts (Pic. 25).

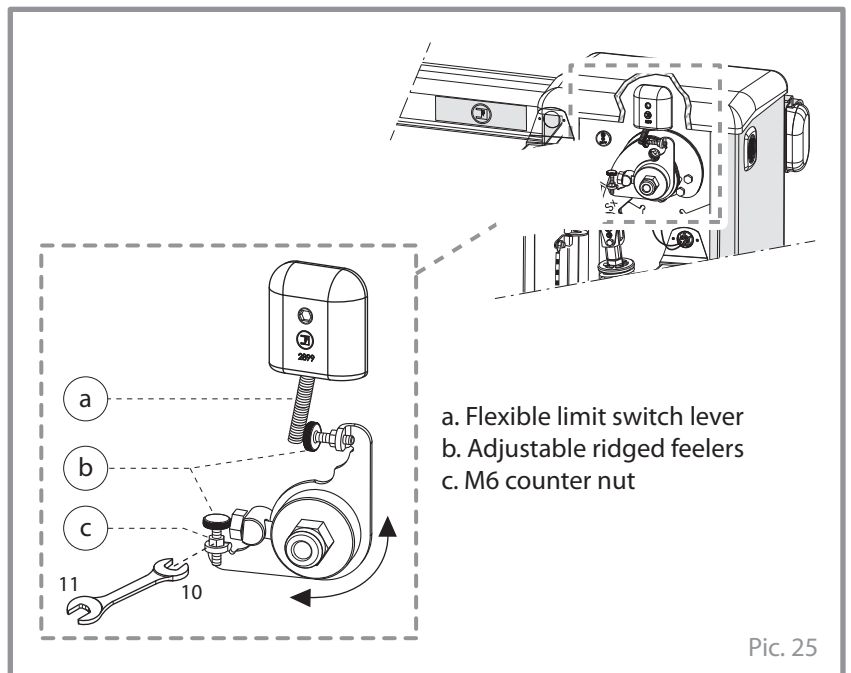

Pic. 25

ORDINARY MAINTENANCE

Periodically it is necessary to perform maintenance to the Bayt 980 barrier and put some grease by means of the greasing nipples factory-fitted to the equipment (Pic. 26).



Important: it is recommended that some grease be put every three months by the greasing nipple as indicated in the two points in the pictures.

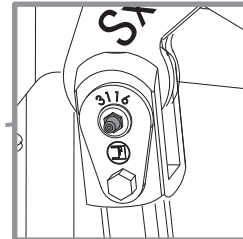
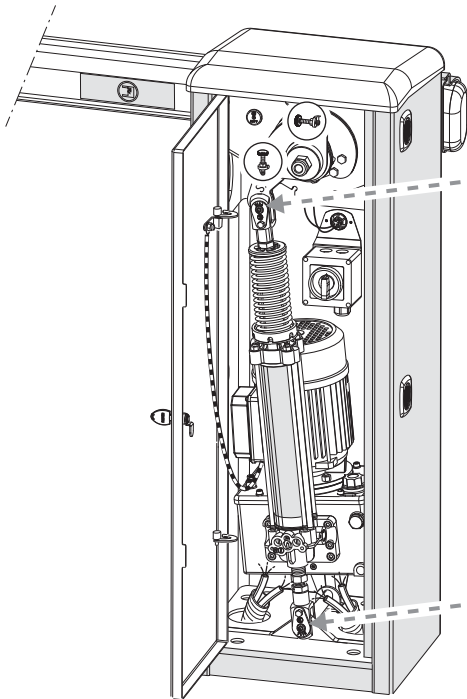

1. Upper attachment pin for the barrier beam command rod-fork-connecting rod

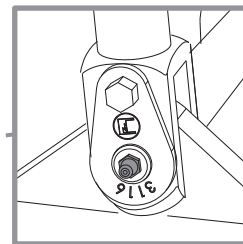

2. Lower attachment pin for fork-reservoir-Cos 982 piston

Pic. 26

ADJUSTMENT OF THE THRUST FORCE



Important: at the moment of the first running test at the factory, the thrust force is calibrated and set as a function of the speed and the length of the barrier beam. Before changing the factory pre-set arrangements on the maximum/minimum oil pressure screws in the valve block, make sure it is absolutely required by the site application; the two adjusting screws, one red and one green, are positioned frontally on the valve block, at the base of the barrier beam actuation piston (Pic. 27).

1. **Red screw:**
adjustment of the opening thrust of the arm
2. **Slowing of the barrier beam:**
tightening increases the braking of the barrier beam, loosening decreases the braking of the barrier beam.
3. **Green screw:**
adjustment of the closing thrust of the arm.
4. **Manual release:**
in the situation in which there is an electrical power failure, it is possible to operate the barrier beam manual by acting on the release valve located between the two screws for maximum and minimum pressure with the specific unlocking spanner; to release: turn the release spanner in an anti-clockwise direction (max. 1-2 turns).

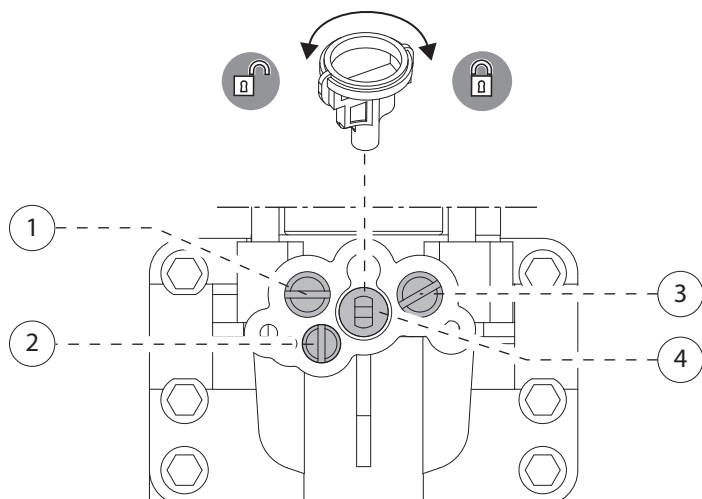

Pic. 27

GENERIC INSTALLATION WITH COUNTERWEIGHTS, CABLES, FENCE AND LED LAMPS

English



Important: dimensions are variable based on the number of counterweights attached. (See table Pic. 34, page 20).

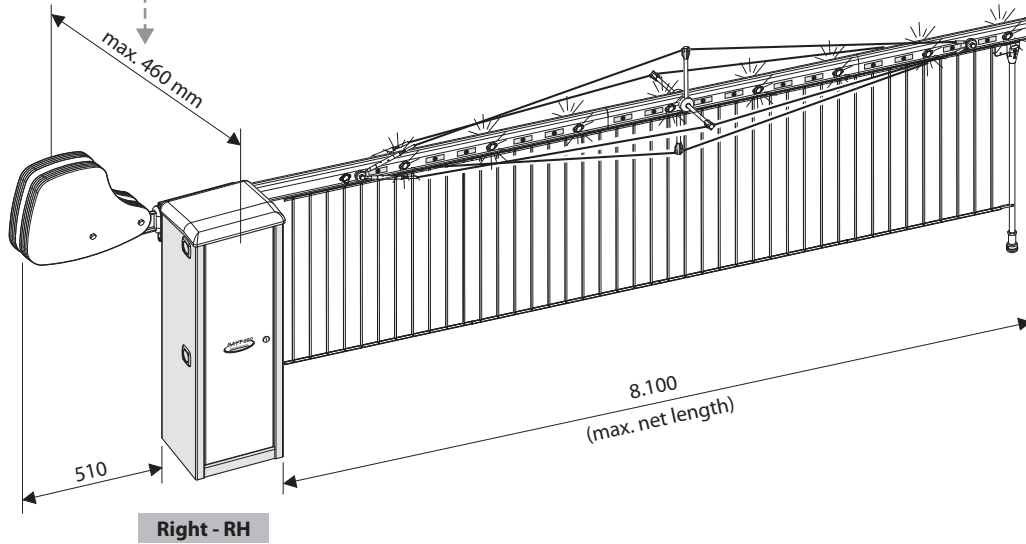

Pic. 28

POSSIBILITY OF INSTALLATION OF THE ALUMINIUM BARRIER BEAM WITH LED LAMPS

In the event of an installation of the Bayt 980 with LED lamps, it is possible to connect the Al.Flex 34 control device and have the lights switching on in series, or all flashing simultaneously (Pic. 29).

- 1. Accessories box
- 2. Elpro 980 electronic programmer
- 3. Cable and terminals set up inside of the housing cabinet for the connection of the led lamps
- 4. Bayt 980 housing cabinet
- 5. Led lamps
- 6. Al.Flex 34

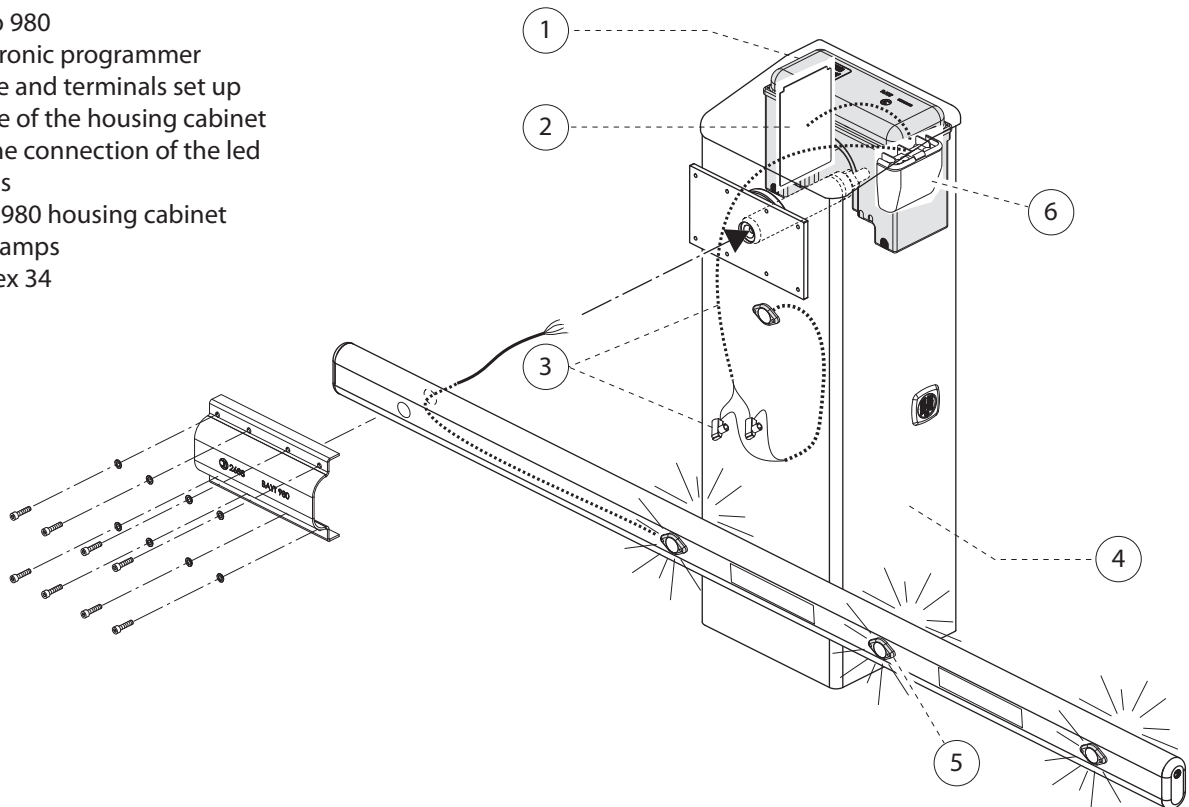

Pic. 29

CONNECTIONS TO THE SIGNALLING LEDS FITTED TO THE BARRIER MOVING BEAM

LED lights are available incorporated into the beams of the road barrier type BAYT 980 allowing for red light or green light (Pic. 30).

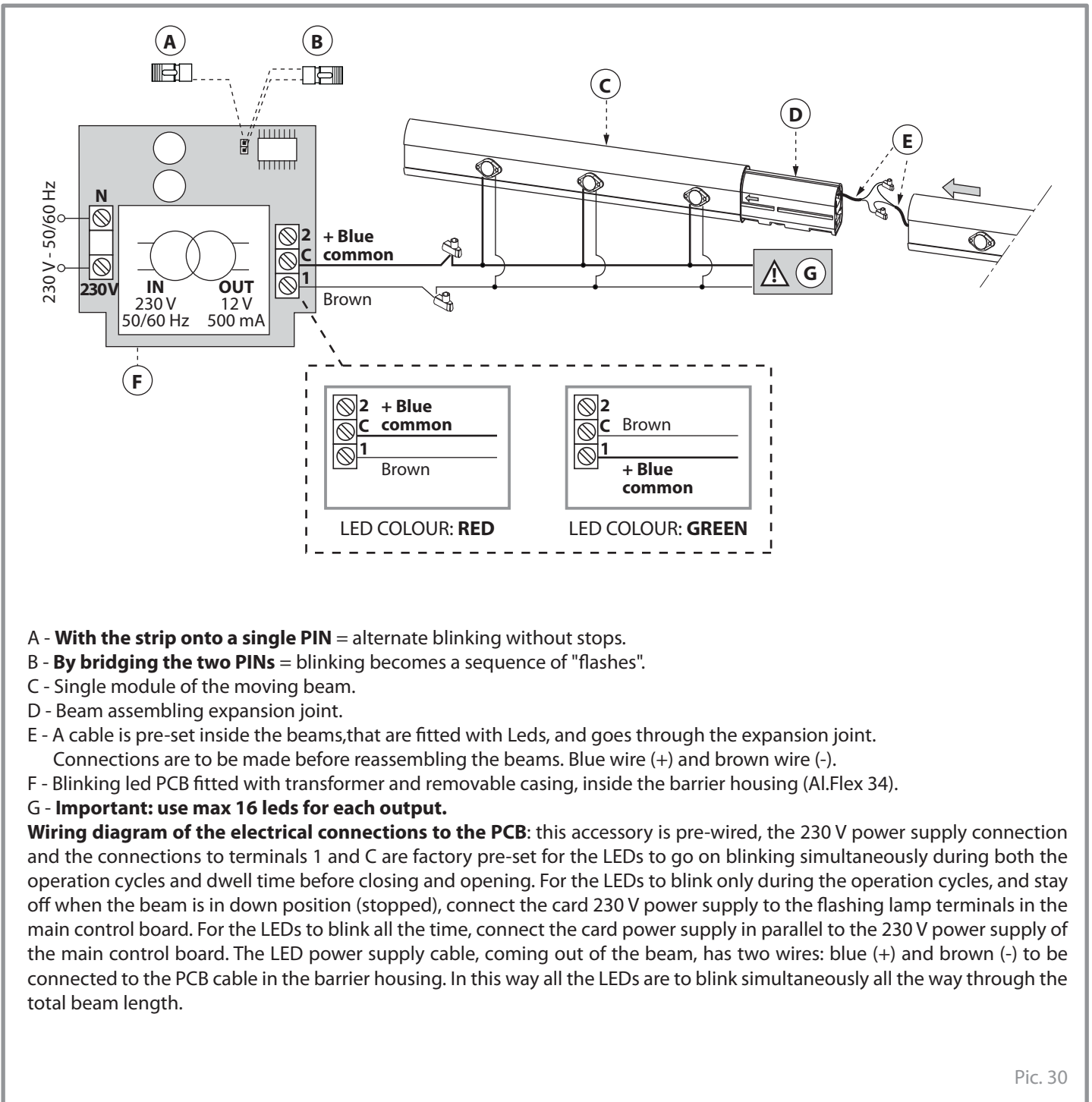

- A - **With the strip onto a single PIN** = alternate blinking without stops.
- B - **By bridging the two PINs** = blinking becomes a sequence of "flashes".
- C - Single module of the moving beam.
- D - Beam assembling expansion joint.
- E - A cable is pre-set inside the beams, that are fitted with Leds, and goes through the expansion joint.
Connections are to be made before reassembling the beams. Blue wire (+) and brown wire (-).
- F - Blinking led PCB fitted with transformer and removable casing, inside the barrier housing (Al.Flex 34).
- G - **Important: use max 16 leds for each output.**

Wiring diagram of the electrical connections to the PCB: this accessory is pre-wired, the 230 V power supply connection and the connections to terminals 1 and C are factory pre-set for the LEDs to go on blinking simultaneously during both the operation cycles and dwell time before closing and opening. For the LEDs to blink only during the operation cycles, and stay off when the beam is in down position (stopped), connect the card 230 V power supply to the flashing lamp terminals in the main control board. For the LEDs to blink all the time, connect the card power supply in parallel to the 230 V power supply of the main control board. The LED power supply cable, coming out of the beam, has two wires: blue (+) and brown (-) to be connected to the PCB cable in the barrier housing. In this way all the LEDs are to blink simultaneously all the way through the total beam length.

Pic. 30

CONNECTIONS TO THE SIGNALLING LEDS FITTED TO THE BARRIER MOVING BEAM (WITH ITEM CODE 7283L)

LED lights are available incorporated into the beams of the road barrier type BAYT 980 allowing for red light (with the beam in horizontal position and on moving) and green light (with the beam in vertical position/gateway cleared). (Pic. 31).

English

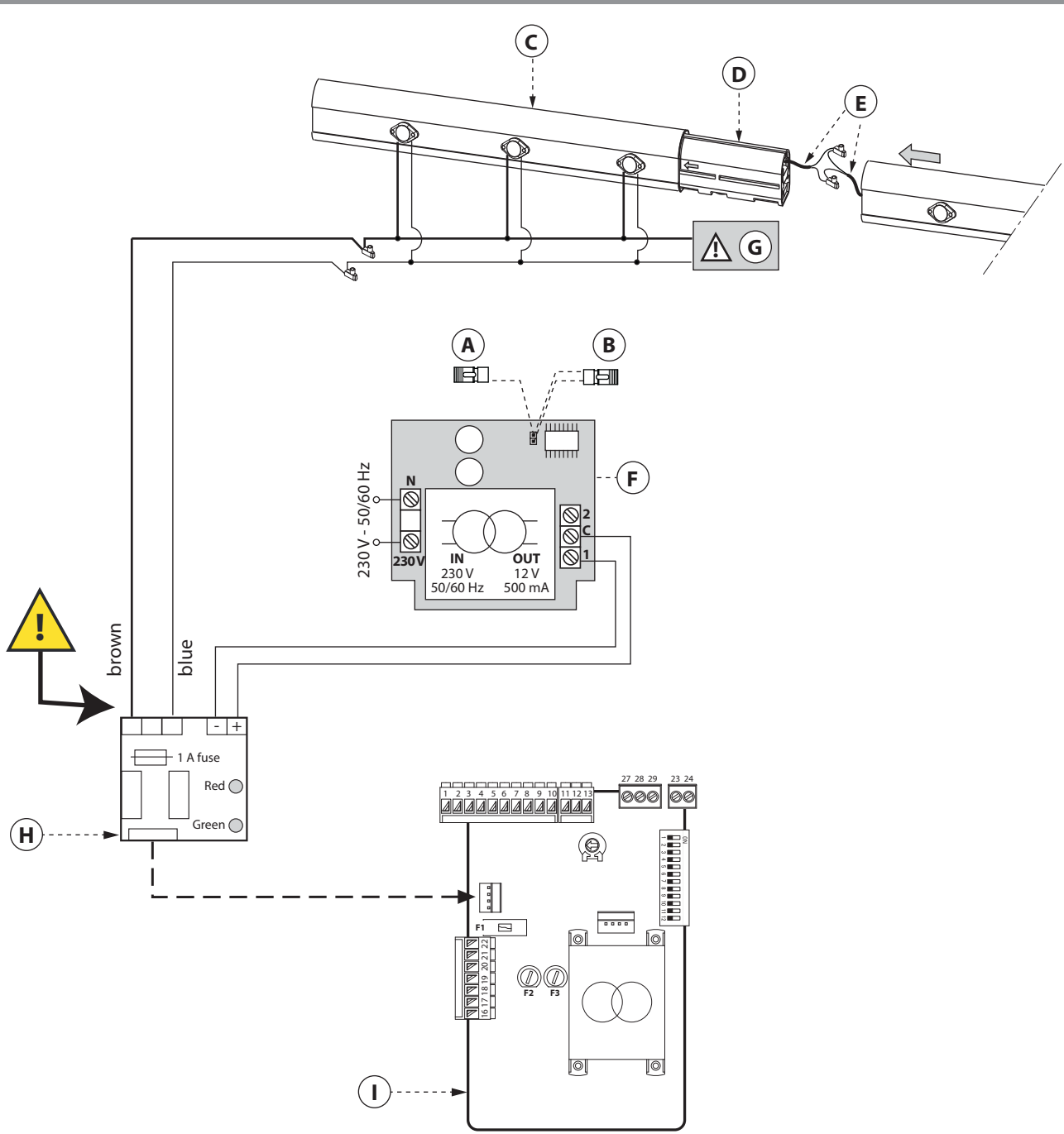

- A - **With the strip onto a single PIN** = alternate blinking without stops.
- B - **By bridging the two PINs** = blinking becomes a sequence of "flashes".
- C - Single module of the moving beam.
- D - Beam assembling expansion joint.
- E - A cable is pre-set inside the beams, that are fitted with LEDs, and goes through the expansion joint. Connections are to be made before reassembling the beams. Blue wire and brown wire.
- F - Blinking led PCB fitted with transformer and removable casing, inside the barrier housing (Al.Flex 34).
- G - **Important: use max 16 leds for each output.**
- H - Plug-in card for red/green light with the LEDs. Code 7283L.
- I - Inner electronic control box Elpro 980.

Wiring diagram of the electrical connections to the PCB for red/green light with the LEDs (code 7283L): the LED power supply cable, coming out of the beam, has two wires: blue and brown to be connected to the plug-in card for red/green light with the LEDs (code 7283L). In this way all the LEDs are to blink simultaneously all the way through the total beam length.

Pic. 31

OVERALL DIMENSIONS FOR THE HOUSING CABINET AND SPECIFIC ACCESSORIES

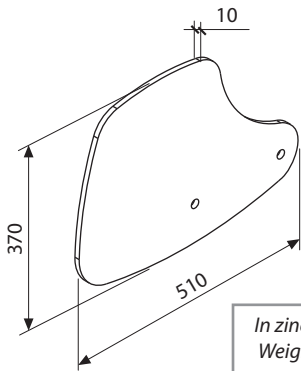
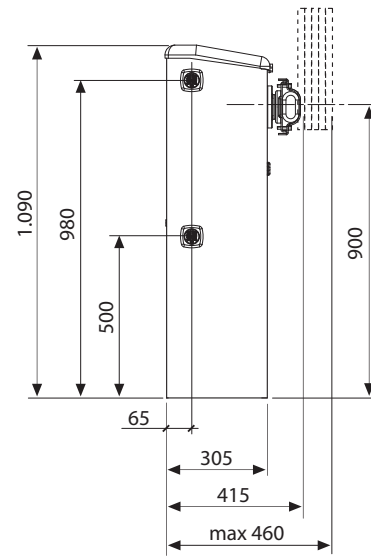
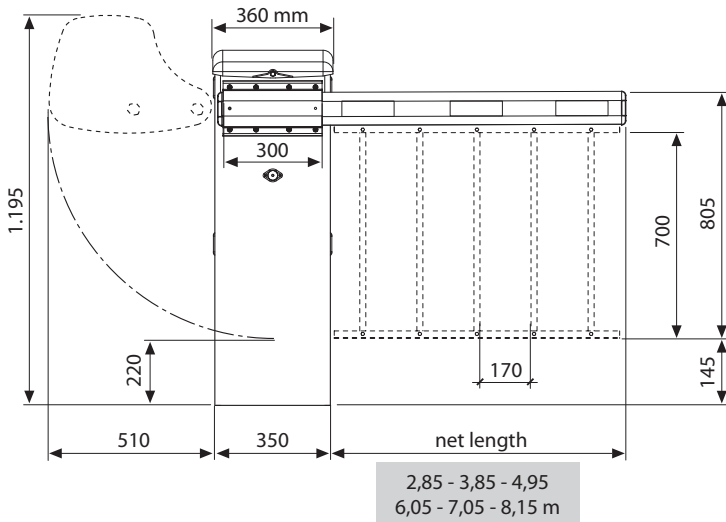

*In zinc-coated iron.
Weight 10 kg each*

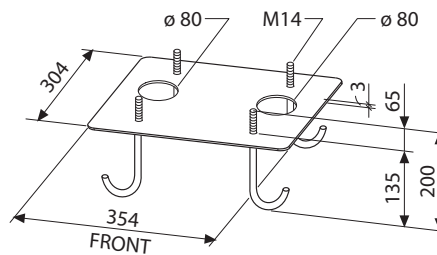

- Zinc-coated anchor bolts: M14x200
- Interaxis bolts holes: 200x200
- Zinc-coated or stainless steel versions

COUNTERWEIGHT

ANCHOR PLATE WITH ANCHOR BOLTS

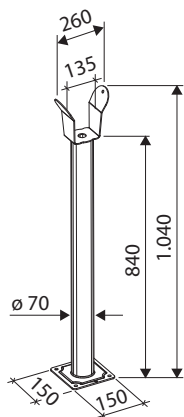

Zinc-coated or stainless steel version

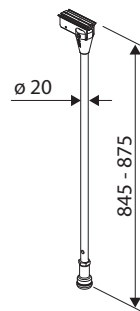

FIXED PEDESTAL WITH FORK

FOLDING LEG

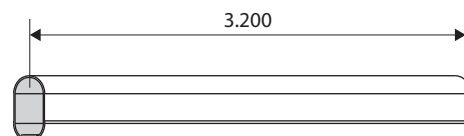
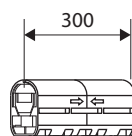
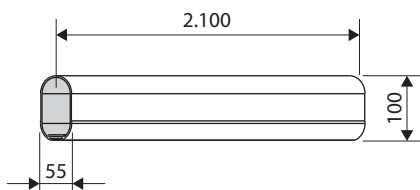

R532 ALUMINIUM BARRIER BEAM

COUPLING CLAMP

English

COS 982 HYDRAULIC DRIVE UNIT OVERALL DIMENSIONS

English

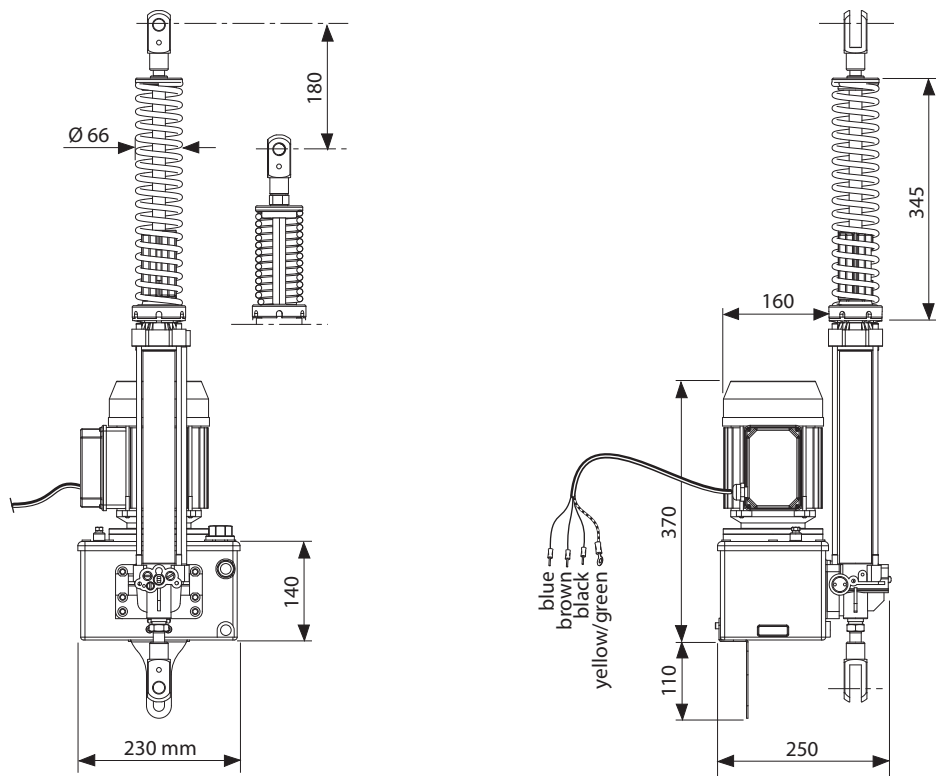

Important: do not put oil into the reservoir. It has already been filled.
To check the oil level in the reservoir of the Cos 982, the piston must be perpendicular to the housing cabinet of the Bayt 980.

Pic. 33

SUMMARY TABLE OF THE POSSIBLE APPLICATIONS

Specifications				Applications					
Speed (s)	Spring	Piston (mm)	Pump	Beam length (m)	Reinforcement beam	Fence	Cable KIT	No. of counterweights (10 kg each plate)	Leds
3		Ø 30	P16	3,20					6
4		Ø 40	P16	3,20					6
				4,20					8
8	✓	Ø 40	P8	4,20		✓			8
				5,30					10
				6,40					12
14	✓	Ø 50	P6	4,20		✓			8
				5,30		✓			10
				6,40	✓	✓		4	12
				7,40	✓		✓	3	14
19	✓	Ø 60	P6	6,40	✓	✓		4	12
				7,40	✓		✓	3	14
				7,40	✓	✓	✓	6	14
				8,50	✓		✓	7	16
				8,50	✓	✓	✓	9	16

Pic. 34

SWING AWAY SYSTEM ALA.180 FOR THE PROTECTION OF THE BEAM AND HOUSING IN CASE OF IMPACT

ALA.180 system, accessory for BAYT 980 (item code No. 9897L), allows the opening (swinging away) of the beam in the direction of the impact with a vehicle and has been designed to protect the main structural components of BAYT 980 barrier and beam. Following an impact it is required that the beam be brought by hand to the original operative position, as described in the instructions in Pic. 40.

Limitations of application with ALA.180 system:

- beam max. length (with or without LED lights): 6,40 m
- beam max. length with a fence (with or without LED lights): 4,20 m

COMPONENTS OF ALA.180 SYSTEM

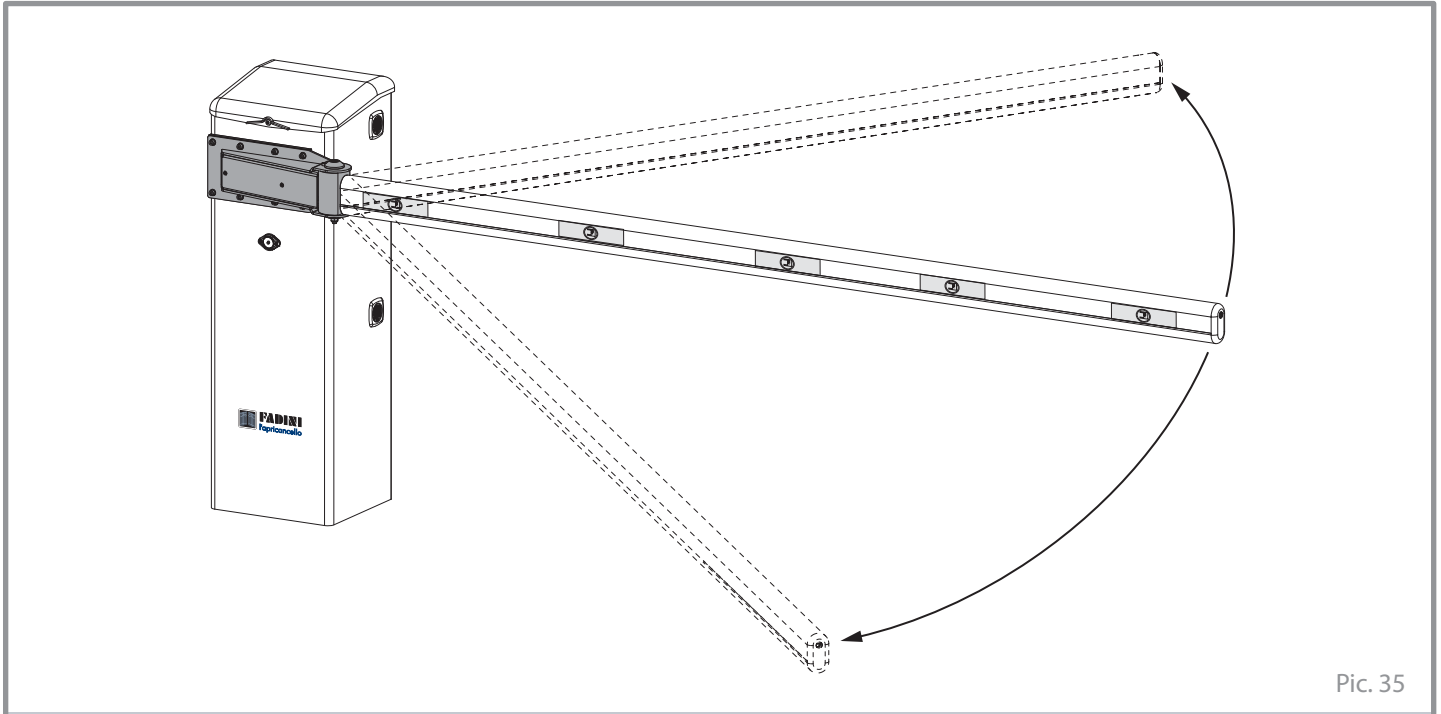

Pic. 35

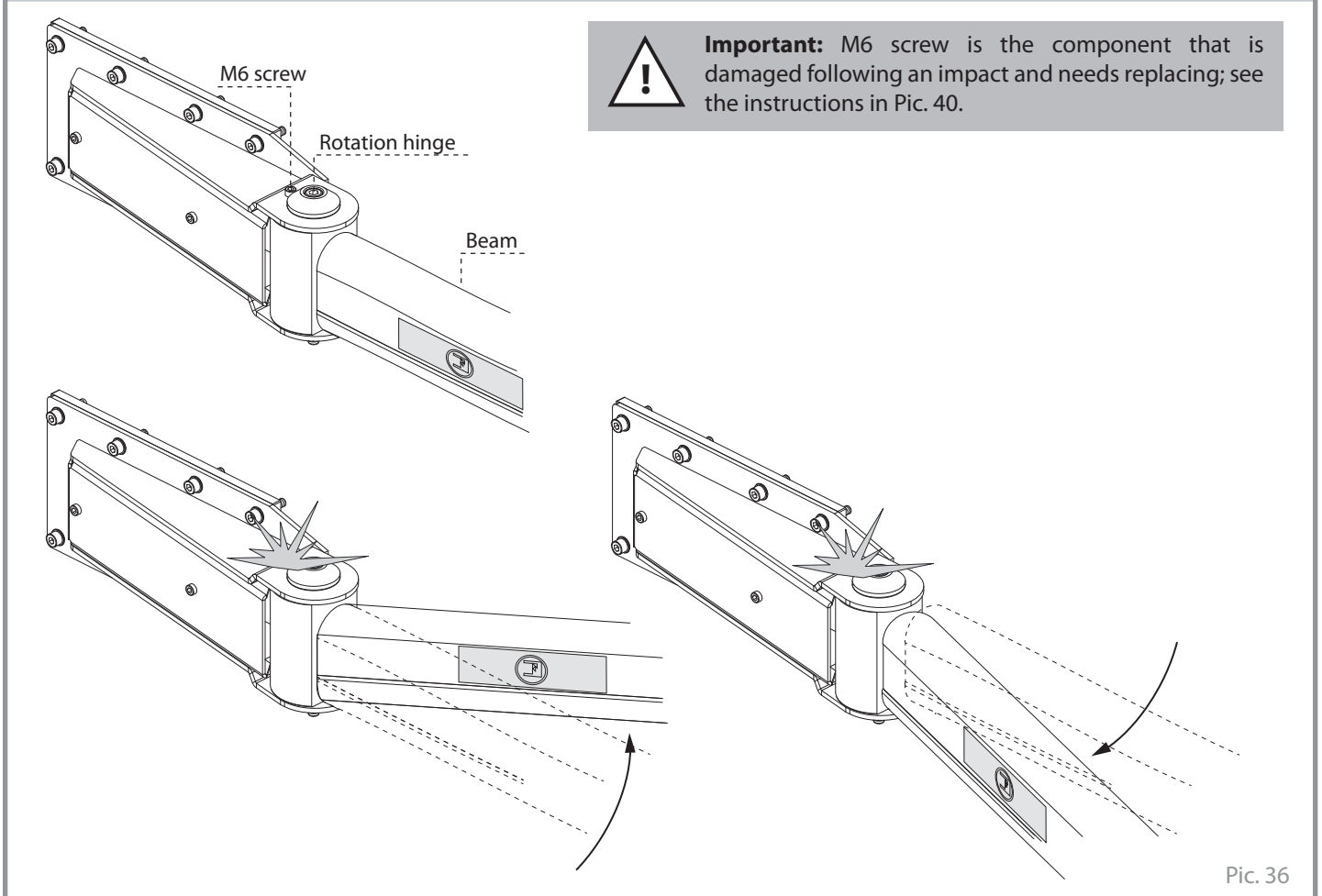

 **Important:** M6 screw is the component that is damaged following an impact and needs replacing; see the instructions in Pic. 40.

Pic. 36

INSTALLATION OF ALA.180

English

! Check the usable length of the beam.

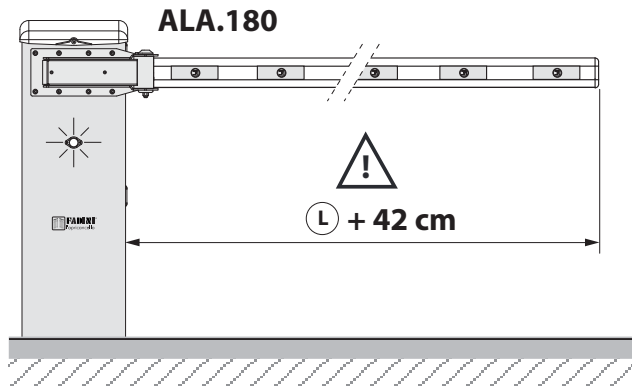
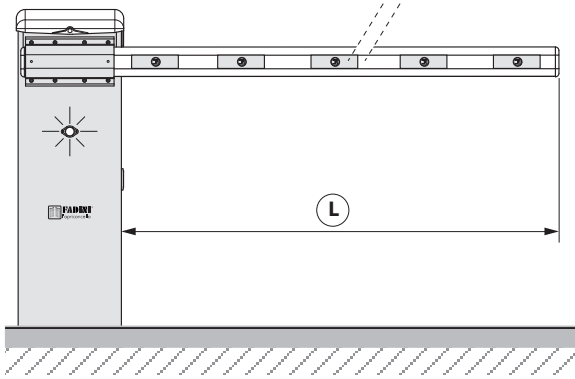

Pic. 37

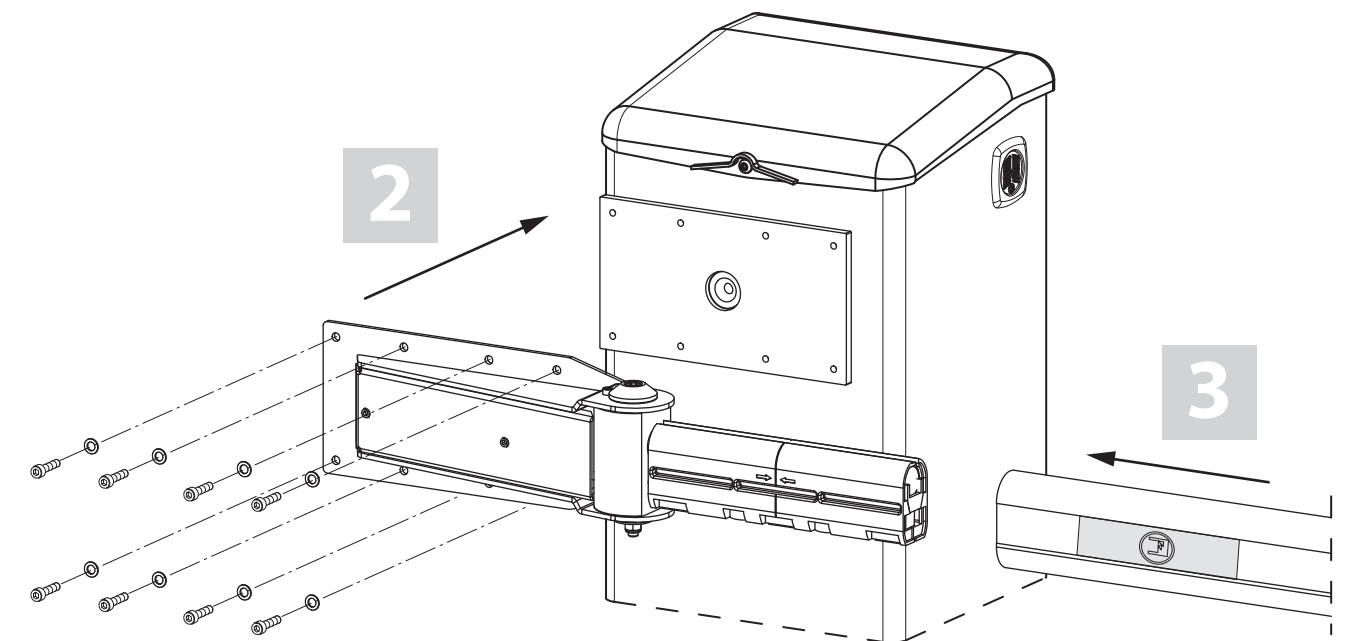
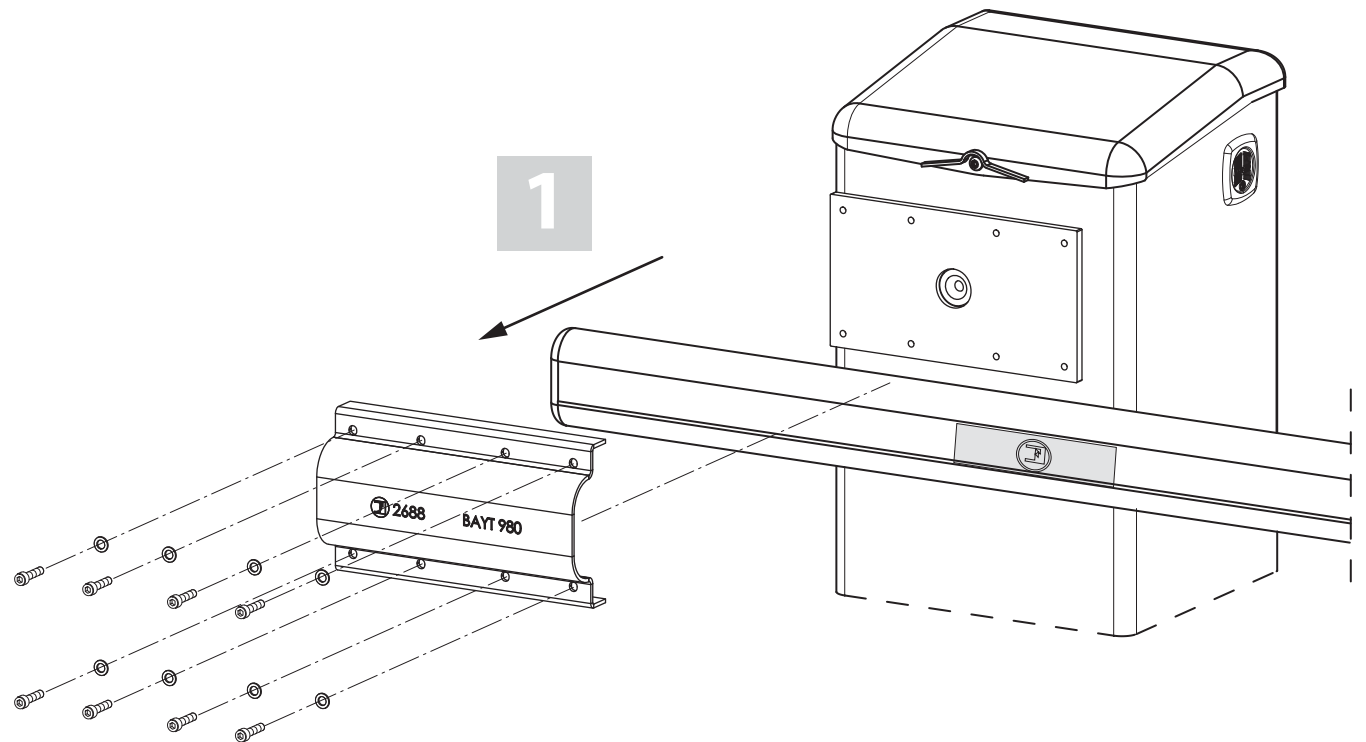

Pic. 38

HOW TO FIX THE BEAM TO ALA.180 SWING AWAY SYSTEM

English

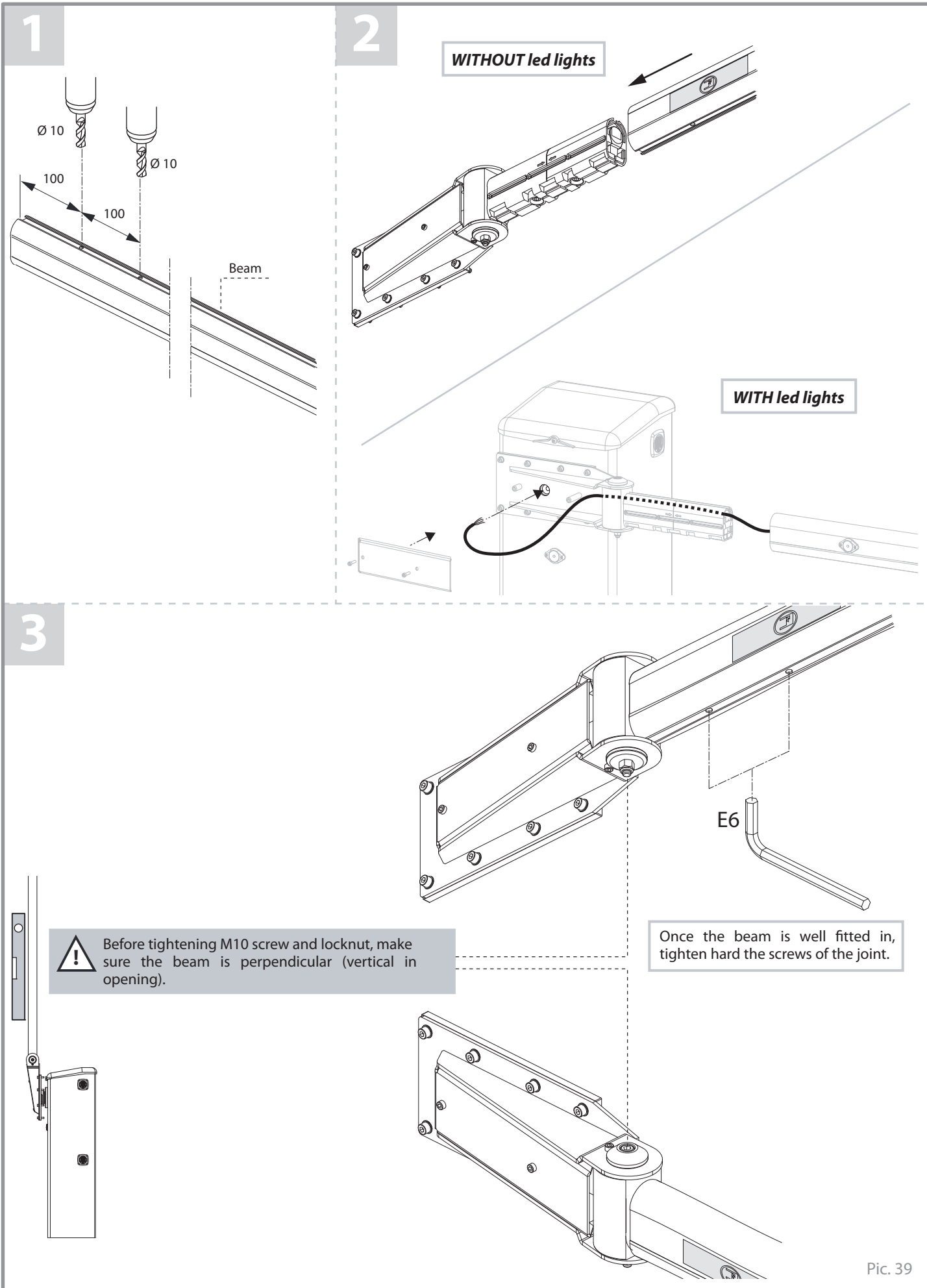

Pic. 39

BRINGING BACK ALA.180 SWING AWAY SYSTEM TO ORIGINAL POSITION, AFTER A COLLISION

English

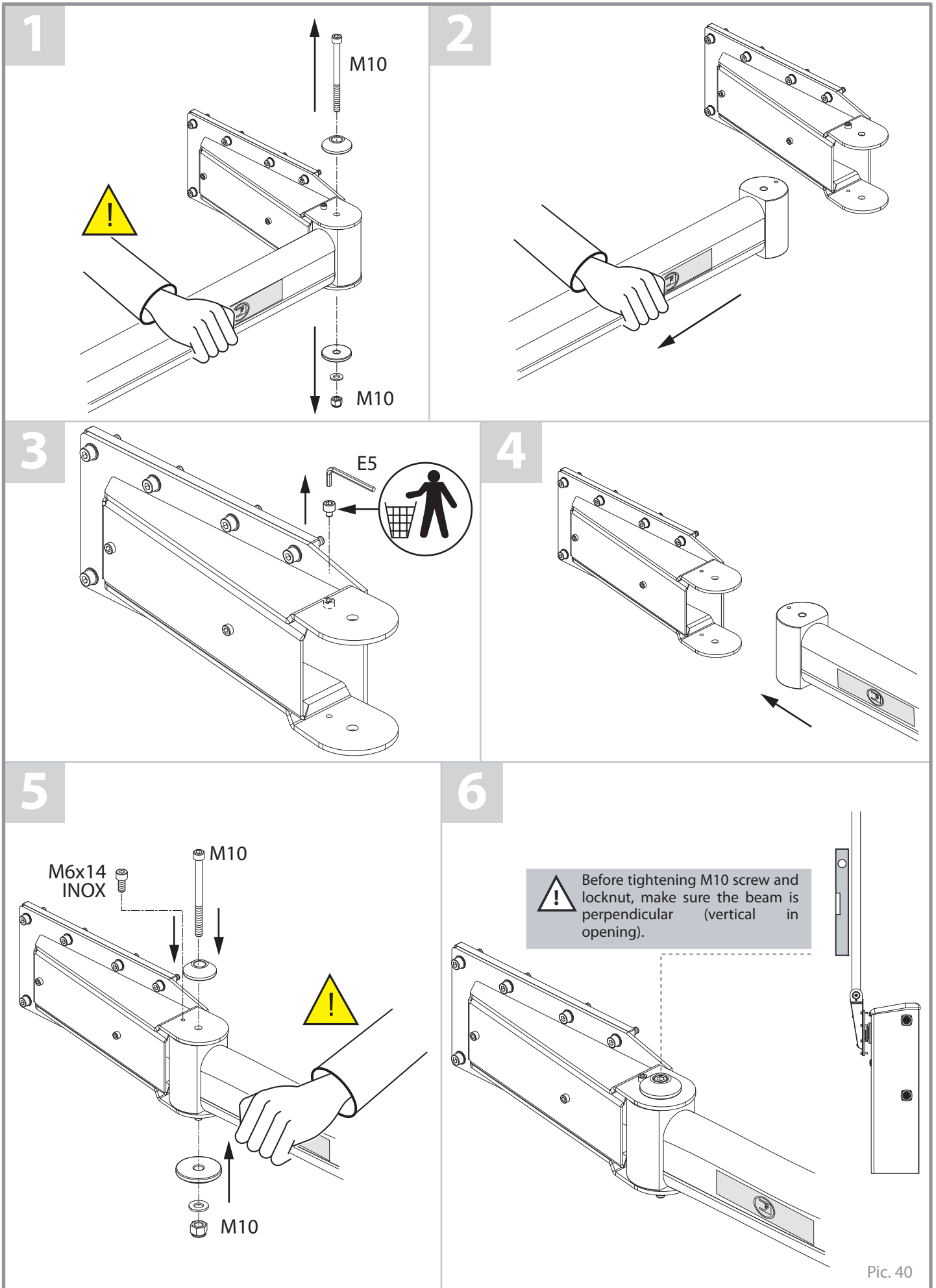

MANUALLY LOCKING AND UNLOCKING BAYT 980

This manual operation is required to be done in case of power failure or problems with the system. Open the door of the housing by the coded key and use the spanner to operate the unlocking/releasing device (located between the red and green adjusting screws). Turn the spanner (max 1 or 2 turns) anti clockwise to unlock/release the unit: the beam can be so operated by hand. Bring the beam to the vertical position and lock the barrier: turn the spanner clockwise by 1 or 2 turns max. To unlock the unit and bring the beam back to horizontal position, operate the release/unlocking device as described before.

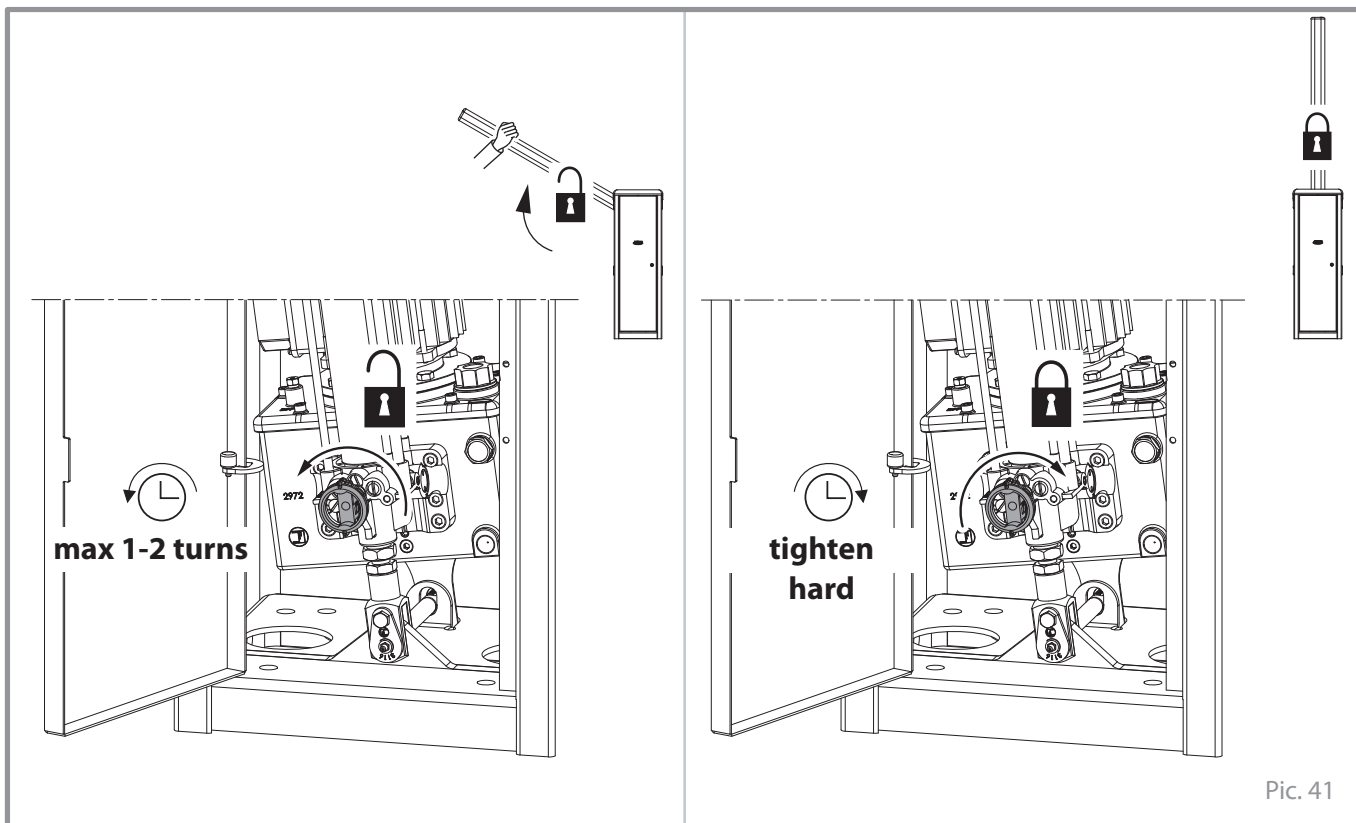

Pic. 41

BAYT 980 WITH SOLENOID VALVE

In case a Bayt 980 barrier fitted with a 24 Vdc solenoid valve is installed and a power failure occurs, it is possible to manually open the beam without having to operate the unlocking/releasing device.

The beam is firmly held in vertical position by the locking device in the hydraulic unit. In order to lower it, it is required that the hydraulic unit be manually released as indicated in Pic. 41. A voltage stabilizer item code No. 9321L is always to be used in association with it.

NOTE: the device is incorporated into the COS 982 pump-actuator assembly by the manufacturer. Though being optional, it can be requested with all BAYT 980 oil-hydraulic barriers on ordering.

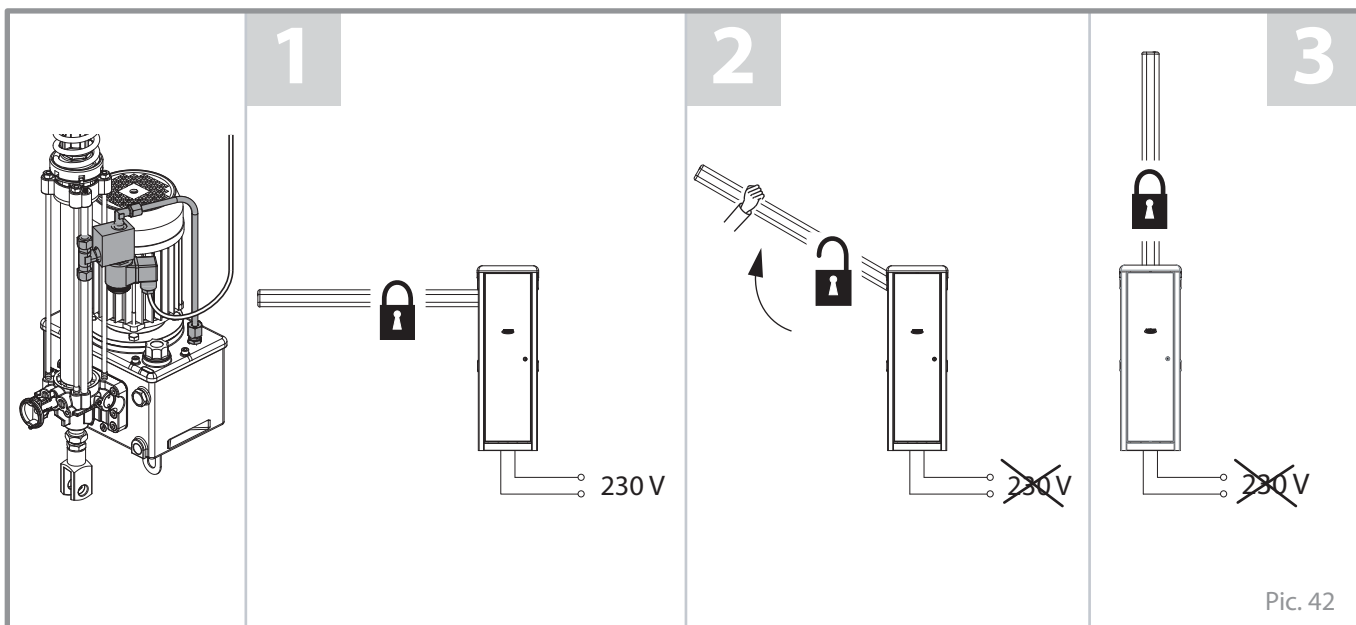

Pic. 42

hand over to the end user of the installation



GUIDANCE FOR PROPER USE (for the end user)**WARNINGS**

- Make sure the site is free from utilities that may interfere with it.
 - Make sure the power supply to the electric motor is 230 V (50 Hz).
- The section of the ground cable is to be chosen in compliance with the requirements of the installation site. As far as configuration and execution of the system are concerned, these are to comply with the laws in the country of installation.**
- Transit across the barrier is allowed only if motor is stopped; stand at safe distance during opening and/or closing cycles of the barrier.
 - Do not touch any components of the system while the operator is working.
 - Do not allow children and/or people to stand in the proximity of a working operator.
 - Keep all the accessories able to turn on the operator (transmitters, proximity readers, key-switches, etc.) out of the reach of the children.
 - Do not run the system in case of anomalies.
- DISPOSAL OF MATERIAL:** dispose properly of the packaging materials such as cardboard, nylon, polystyrene etc. through specializing companies (after verification of the regulations in force at the place of installation in the field of waste disposal). Disposal of electrical and electronic materials: to remove and dispose through specializing companies, as per Directive 2012/19/UE. Disposal of substances hazardous for the environment is prohibited.

MAINTENANCE

For optimum performance of system over time according to safety regulations, it is necessary to perform proper maintenance and monitoring of the entire installation: the automation, the electronic equipment and the cables connected to these. The entire installation must be carried out by qualified technical personnel. Operator: maintenance inspection at least every 6 months, while for the electronic equipment and safety systems an inspection at least once every month is required. The manufacturer, Meccanica Fadini S.r.l., is not responsible for non-observance of good installation practice and incorrect maintenance of the installation.

- Check the tightening of the bolts.
- Lubricate the indicated mechanical parts with grease (Pic. 26).
- Check the correct functioning of the micro connected to the forced disconnection switch of the power supply.
- Check the correct functioning of the limit switch micro.

Advice for the end user:

- clear the site of materials that may have deposited in the equipment and hinder its correct functioning (such as rests of insects, foliage, stones, etc.); before carrying out this operation, switch off voltage supply;
- clean regularly the equipment by using a damp cloth. Do not use flammable substances such as alcohol, solvents or benzene: these substances may cause explosions and/or damage the system.

PRODUCT SPECIFICATIONS

Oil-hydraulic road barrier with traffic stopping beams whose length range is 3 m to 8 m, very heavy duty. Oil-hydraulic unit consisting of one motor pump assembly incorporating a piston actuator. Suitable for applications in private, commercial industrial areas, car parks and urban applications. IP65. Overall dimensions 350 x 305 x H 1.090 mm. Anodized aluminium beam, oval section. Reinforced, S235JR steel structure, cathaphoresis treated and powder coated. Available in AISI 304 brushed stainless steel. Incorporated control board. Opening time from 2 s to 19 s, depending on beam type. Frequency of use 3.000 cycles/day (version 8 s). Supply voltage 230 Vac \pm 10%, 50 Hz. Absorbed power 510 W. Working temperature -40 °C +80 °C. Beam options available with incorporated high visibility LEDs, fence, articulated joint (for installations with ceiling limitations), swing away arm system in case of impact with a vehicle. Manual release device inside the housing.

hand over to the end user of the installation

English

MAINTENANCE RECORD hand over to the end user of the installation		
--	--	--

Installation address:	Maintainer:	Date:
-----------------------	-------------	-------

Installation type: Sliding gate <input type="checkbox"/> Folding door <input type="checkbox"/> Swinging gate <input type="checkbox"/> Road barrier <input checked="" type="checkbox"/> Over-head door <input type="checkbox"/> Bollard <input type="checkbox"/> Lateral folding door <input type="checkbox"/> <input type="checkbox"/>	Operator model: Dimensions per gate leaf: Weight per gate leaf:	Quantity of models installed: Installation date:
--	---	---

NOTE WELL: this document must record any ordinary and extraordinary services including installation, maintenance, repairs and replacements to be made only by using Fadini original spare parts. This document, for the data included in it, must be made available to authorized inspectors/officers, and a copy of it must be handed over the end user/s.

The installer/maintainer are liable for the functionalities and safety features of the installation only if maintenance is carried on by qualified technical people appointed by themselves and agreed upon with the end user/s.

N°	Service date	Service description	Technical maintainer	End user/s
1				
2				
3				
4				
5				
6				

 Stamp and signature
 installation technician/maintainer

 Signed for acceptance
 end user
 buyer



MCBF

Average life (cycles)	4.000.000
Length of the beam up to 4,2 m	
Folding pedestal	-15% ÷ -20%
Fence	-25% ÷ -30%
Articulated joint rod	-25% ÷ -30%

The MCBF value refers to the road barrier only and does not include any applicable accessories.

BAYT 980 has been designed to perform up to 4.000.000 million cycles, thanks to the hydraulic power unit with 230 Vac servo-ventilated electric motor and hydraulic piston with long-life spring.

It is important to note that the average product lifespan is not a warranty for the product. Please note that the indicated average lifespan of the product is purely indicative. It applies to normal usage conditions, provided that the product has been installed and maintained in accordance with the instructions provided in the FADINI instruction booklet (page 26). The average product lifespan can also be significantly influenced by other variables, such as climatic and environmental conditions, for example. The percentages indicate how much to reduce the number of cycles in relation to the type of installation, beam and accessories.

TECHNICAL SPECIFICATIONS

ELECTRIC MOTOR		OIL-HYDRAULIC MOTOR-PUMP UNIT - COS 982 -			
Power yield	0,37 kW (0,5 HP)	Working pressure	20 atm		
Absorbed power	510 W	Max. pressure	40 atm		
Frequency	50 Hz	Pump	P6 - P8 - P16 - P20		
Supply voltage	230 Vac	Oil type	Oil Fadini - Item 708L		
Absorbed current	2,4 A	Reservoir capacity	2,4 ÷ 2,8 liters		
Capacitor	25 µF	Static weight	22,5 kg		
Motor rotation speed	1.350 rpm	Working temperature	-20 °C +80 °C [A]		
Intermittent service	S3	Protection standards	IP 65 (inside the housing)		
Electric cable	H05VV-F	[A]: -40 °C with specific optional accessories (Ref. General Catalogue).			
Housing weight (without beam)	75 kg				
Colour of the housing	RAL 2002 Orange Red (for Bayt 980 painted)				
Door and top colour	Metallic grey, orange peel finish (for Bayt 980 painted)				
Housing, door and top	Aisi 304 inox, brushed (for Bayt 980 stainless steel)				
PERFORMANCE					
Opening time	2 s	4 s	8 s	14 s	19 s
Cycles/hour	514	300	171	95	75
Cycles/day	7.700	5.600	2.800	1.500	1.200